

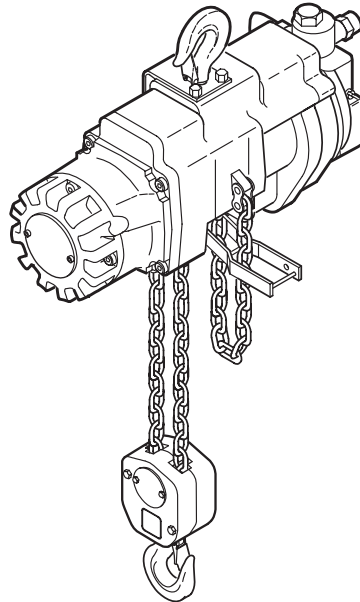

Form P6587
03963832
Edition 12
September 2018

Air Chain Hoist

HLK Series



Operation and Maintenance Manual

EN Operation and Maintenance

ZH 操作和维护指



Save these Instructions

IR Ingersoll Rand®

SAFETY INFORMATION

This manual provides important information for all personnel involved with the safe installation, operation and proper maintenance of this product. Even if you feel you are familiar with this or similar equipment, you should read this manual before operating the balancer.

■ Danger, Warning, Caution and Notice

Throughout this manual there are steps and procedures which, if not followed, may result in an injury. The following signal words are used to identify the level of potential hazard.

 **DANGER** Indicates an imminently hazardous situation which, if not avoided, will result in death or serious injury.

 **WARNING** Indicates a potentially hazardous situation which, if not avoided, could result in death or serious injury.

 **CAUTION** Indicates a potentially hazardous situation which, if not avoided, may result in minor or moderate injury or property damage.

NOTICE Indicates information or a company policy that relates directly or indirectly to the safety of personnel or protection of property.

■ Safety Summary

 **WARNING**

- **Do not use this hoist or attached equipment for lifting, supporting, or transporting people or lifting or supporting loads over people.**
- **Powered hoists are designed to provide a 5 to 1 safety factor. The supporting structures and load-attaching devices used in conjunction with this hoist must provide adequate support to handle all hoist operations plus the weight of the hoist and attached equipment. This is the customer's responsibility. If in doubt, consult a registered structural engineer.**

NOTICE

- **Lifting equipment is subject to different regulations in each country. These regulations may not be specified in this manual.**

The National Safety Council, Accident Prevention Manual for Industrial Operations, Eighth Edition and other recognized safety sources make a common point: Employees who work near suspended loads or assist in hooking on or arranging a load should be instructed to keep out from under the load. From a safety standpoint, one factor is paramount: conduct all lifting operations in such a manner that if there were an equipment failure, no personnel would be injured. This means keep out from under a raised load and keep out of the line of force of any load.

Ingersoll Rand Material Handling hoists are manufactured in accordance with the latest ASME B30.16 standards.

The Occupational Safety and Health Act of 1970 generally places the burden of compliance with the owner/employer, not the manufacturer. Many OSHA requirements are not concerned or connected with the manufactured product but are, rather, associated with the final installation. It is the owner's and user's responsibility to determine the suitability of a product for any particular use. It is recommended that all applicable industry, trade association, federal, state, and local regulations be checked. Read all operating instructions and warnings before operation.

Rigging: It is the responsibility of the operator to exercise caution, use common sense and be familiar with proper rigging techniques. See ASME B30.9 for rigging information, American National Standards Institute, 1430 Broadway, New York, NY 10018.

This manual has been produced by **Ingersoll Rand** to provide dealers, mechanics, operators and company personnel with the information required to install, operate, maintain and repair the products described herein.

It is extremely important that mechanics and operators be familiar with the servicing procedures of these products, or like or similar products, and are physically capable of conducting the procedures. These personnel shall have a general working knowledge that includes:

1. Proper and safe use and application of mechanics common hands tools as well as special **Ingersoll Rand** or recommended tools.
2. Safety procedures, precautions and work habits established by accepted industry standards.

Ingersoll Rand cannot know of, or provide all the procedures by which product operations or repairs may be conducted and the hazards and/or results of each method. If operation or maintenance procedures not specifically recommended by the manufacturer are conducted, it must be make sure that product safety is not endangered by the actions taken. If unsure of an operation or maintenance procedure or step, personnel should place the product in a safe condition and contact supervisors and/or the factory for technical assistance.

SAFE OPERATING INSTRUCTIONS

The following warnings and operating instructions have been adapted in part from American National (Safety) Standards and are intended to avoid unsafe operating practices which might lead to injury or property damage.

Ingersoll Rand recognizes that most companies who use hoists have a safety program in force in their plants. In the event you are aware that some conflict exists between a rule set forth in this publication and a similar rule already set by an individual company, the more stringent of the two should take precedence.

Safe Operating Instructions are provided to make an operator aware of dangerous practices to avoid and are not necessarily limited to the following list. Refer to specific sections in the manual for additional safety information.

1. Only allow personnel instructed in safety and operation on this product to operate and maintain the hoist.
2. Only operate a hoist if you are physically fit to do so.
3. When a **"DO NOT OPERATE"** sign is placed on the hoist controls, do not operate the hoist until the sign has been removed by designated personnel.
4. Read the manufacturer's operating instructions before operating the hoist.
5. Never lift a load greater than the rated capacity of the hoist (unless for test purposes).
6. Never use the load chain as a sling.
7. Never operate the hoist with twisted, kinked, "capsized" or damaged chain.
8. Be certain the load is properly seated in the saddle of the hook.
9. Do not use load chain as a ground for welding. Do not attach a welding electrode to a hoist or sling chain.
10. Do not use the up and down stops as a means of stopping a hoist. The up and down stops are emergency devices only.
11. Do not leave a load suspended for extended periods.
12. Always stand clear of the load path.
13. Never use the hoist for lifting or lowering people, and never stand on a suspended load.
14. Never carry loads over people.
15. Before each shift, check the hoist for wear or damage. Check brakes, limit stops, etc.
16. Periodically, inspect the hoist thoroughly and replace worn or damaged parts.
17. Follow the lubrication instructions.
18. Do not attempt to repair load chain or hooks. Replace them when they become worn or damaged.
19. Never operate a hoist when the load chain is not centered under the hook. Do not "side pull" or "yard".
20. Always rig the hoist properly and carefully.
21. Ease the slack out of the load chain when starting a lift. Do not jerk the hoist load.
22. Keep the load chain clean and well lubricated. Do not drag the load chain or hook on the floor.
23. Be certain there are no objects in the way of a moving load.
24. Be certain the air supply is shut off before performing maintenance on the hoist.
25. Do not swing a suspended load.
26. Keep the load block overhead when not in use.
27. After use, or when in a non-operational mode, the winch should be secured against unauthorized and unwarranted use.
28. Avoid collision or bumping of hoists.
29. Pay attention to the load at all times when operating a hoist.
30. Never splice a hoist chain by inserting a bolt between links or by any other means.
31. Do not force a chain or hook into place by hammering, and never insert the point of the hook into a chain link.
32. Do not allow the chain to be exposed to extremely cold weather. Do not apply loads to a cold chain.

SPECIFICATIONS

Table 1

Hoist Model No.	Rated Capacity (kg)	No. Chain Falls	Speed with Rated Load				Speed with Half Load				Speed with No Load				Hoist Weight*	
			fpm		m/m		fpm		m/m		fpm		m/m		lb	kgs
			up	down	up	down	up	down	up	down	up	down				
HL1000K	1000	1	26	37	7.9	11.3	31	30	9.4	9.1	40	26	12.2	7.9	84	38.1
HL1000KR			16	26	4.9	7.9	22	22	6.7	6.7	28	16	8.5	4.9		
HL1500K	1500	2	13	18	4.0	5.5	15	15	4.6	4.6	20	13	6.1	4.0	125	56.6
HL2000K	2000		8	13	2.4	4.0	11	11	3.4	3.4	14	8	4.3	2.4	129	58.5
HL3000K	3000	3	4.6	10	1.4	3.0	7.5	8.4	2.3	2.6	10.5	6.6	3.2	2.0	193	87.5
HL4500K	4500	4	3.5	7.6	1.0	2.3	5.8	6.2	1.8	1.9	8.4	4.8	2.6	1.5	248	112.5

Notes:

* Based on hook mounted hoist with standard 10 ft (3 m) lift and one motor pendant control.

** Performance figures based on 70 SCFM (1.96 cu m/min) at 90 psig (6.3 bar/630 kPa) air supply at hoist inlet. Pendant control models use approximately 4 SCFM (0.11 cu m/min) more air.

Model Code Explanation:

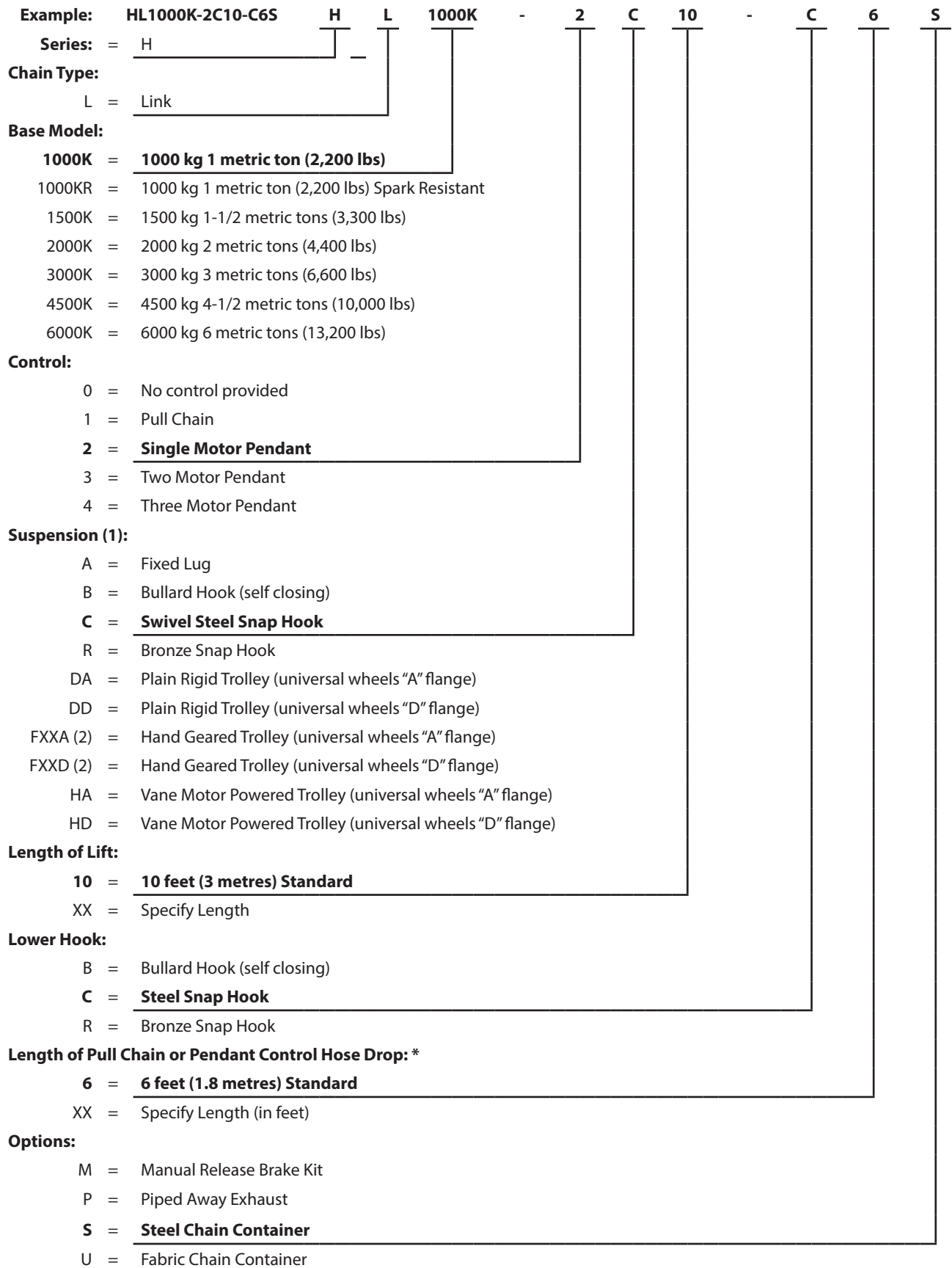

1. XX = Specify length of hand chain required. Example: "08" = 8 feet, standard.
2. Order hose lengths in feet. Metric sizes listed for reference only.

INSTALLATION

Prior to installing the hoist, carefully inspect it for possible shipping damage.

Hoists are supplied fully lubricated from the factory. Lubrication of the load chain is recommended before initial hoist operation.

CAUTION

- **Owners and users are advised to examine specific, local or other regulations, including American National Standards Institute and/or OSHA Regulations which may apply to a particular type of use of this product before installing or putting hoist to use.**

WARNING

- **A falling load can cause injury or death. Before installing, read "SAFETY INFORMATION".**
- **The supporting structures and load-attaching devices used in conjunction with this hoist must provide adequate support to handle all hoist operations plus the weight of the hoist and attached equipment. This is the customer's responsibility. If in doubt, consult a registered structural engineer.**

Hoist Checks

Make certain your hoist is properly installed. A little extra time and effort in so doing can contribute toward preventing accidents and helping you get the best service possible. Always make certain the supporting member from which the hoist is suspended is strong enough to support the weight of the hoist plus the weight of a maximum rated load plus a liberal safety factor.

CAUTION

- **Before placing this hoist in service, remove square headed pipe plug from oil fill hole and replace with hex headed breather plug attached to caution tag CA210-121.**
1. Remove the solid shipping plug located on top of the hoist and install the attached breather plug prior to using the hoist.
 2. With the hoist placed in its normal level position check that the gear case oil level is at the check plug on the side of the gear box.

Hoist Mounting

Hook Mounted Hoist Installation

Place hook over mounting structure. Make sure hook is large enough to properly fit on structure. Make sure hook latch is engaged.

Make sure the supporting member rests completely within the saddle of the hook and is centered directly above the hook shank. Hoist must freely hang from hook without restriction.

CAUTION

- **The supporting member must position on the saddle of the hook. Make sure hoist does not tilt to one side or the other.**

Trolley Mounted Hoist Installation

Refer to Dwg. MHP0866.

When installing a trolley on a beam, measure the beam flange and temporarily install the trolley on the hoist to determine the exact distribution and arrangement of the spacers. The total distance between the wheel flanges should be $3/16$ to $1/4$ inch (5 to 6 mm) greater than the width of the beam flange. The number of spacers between the trolley side plate and the mounting lug on the hoist must be the same in all four locations in order to keep the hoist centered under the I-beam. The remaining spacers must be equally distributed on the outside of the trolley side plates.

NOTICE

- **For specific information relating to trolley installation refer to the manufacturers' manual supplied with the trolley.**

HLK Hoist Plain Rigid Trolley

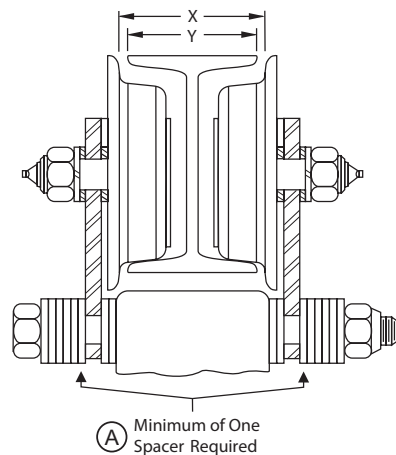

(Dwg. MHP0866)

Note: Make sure $X-Y=3/16$ to $1/4$ inch (5 to 6 mm)

WARNING

- **A minimum of one adjusting spacer must be placed on the outside of the trolley side plates. Make sure correct installation as described in the parts, operation and maintenance manual provided with the trolley.**

Trolley bolt nuts (207) and (220) torque requirements:

On HL1000K, HL1500K, HL2000K and HL3000K hoists torque to 150 ft lbs (203 Nm).

On HL4500K and HL6000K hoists torque to 250 ft lbs (339 Nm).

When installing the hoist and trolley on the beam, make certain the side plates are parallel and vertical. After installation, operate the trolley over the entire length of the beam with rated load suspended 4 to 6 inches (100 to 150 mm) off the floor.

CAUTION

- **To avoid an unbalanced load which may damage the trolley, the hoist must be centered under the trolley.**

NOTICE

- **Trolley wheels ride on the top of the lower flange of the beam.**

Make sure beam stops are installed prior to operating hoist and trolley.

■ Chain Container

Refer to "MAINTENANCE" section and Dwgs. MHP4303 and TPC451-3 for detailed assembly and disassembly information.

NOTICE

- **Make certain to adjust the container support such that the chain container does not contact the load chain or hook.**
 - **Operate the hoist to naturally pile chain into the chain container. Piling the chain carelessly into the container by hand may lead to kinking or twisting that may cause chain to jam the hoist.**
1. Check the chain container size to make sure the length of load chain is within the capacity of the chain container. Replace with a larger chain container, if required.
 2. Attach the chain container to the hoist.
 3. Run bottom block to lowest point and run hoist in up direction to feed the chain back into the container.

WARNING

- **Disconnect the hoist from the air supply before installing a chain container kit.**

■ Air System

The supply air must be clean, lubricated and free from water or moisture. A minimum air supply of 70 scfm (1.96 cu. m/m) at 90 psig (6.3 bar/630 kPa) at the hoist motor inlet is required, during operation to provide rated hoist performance.

■ Air Lines

The inside diameter of the hoist air supply lines must not be smaller than 1/2 in (13 mm) for up to 12 ft (4 m) lengths and 3/4 in (19 mm) for up to 50 ft (15 m) lengths between the air supply and the hoist. Contact the factory for recommended air line sizes for distances greater than 50 ft (15 m). Before making final connections, all air supply lines should be purged with clean, moisture free air before connecting to unit inlet. Supply lines should be as short and straight as installation conditions will permit. Long transmission lines and excessive use of fittings, elbows, tees, globe valves, etc. cause a reduction in pressure due to restrictions and surface friction in the lines. Fittings used at the inlet of the hoist must have at least a 3/8 in (10 mm) air passage. Use of smaller fittings will reduce performance.

NOTICE

- **Always use an air line filter and lubricator with an HLK hoist.**

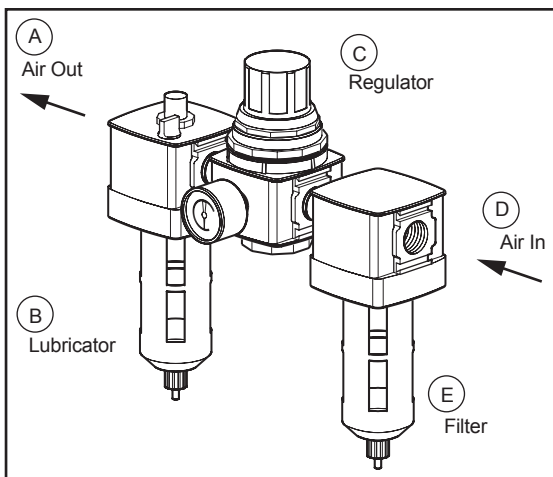

(Dwg. MHP0191)

■ Air Line Lubricator

Refer to Dwg. MHP0191.

Always use an air line lubricator with these hoists. Use a lubricator having an inlet and outlet at least as large as the inlet on the hoist motor. Install the air line lubricator as close to the air inlet on the hoist motor as possible. Refer to "ACCESSORIES" in the parts section for the recommended Filter-Lubricator-Regulator.

CAUTION

- **Lubricator must be located no more than 10 ft (3 metres) from the hoist motor.**
- **Shut off air supply before filling air line lubricator.**

The air line lubricator should be replenished daily and set to provide lubrication at a minimum rate of 1 to 3 drops per minute adjusted at maximum hoist speed, of SAE 10W oil or a good grade of hydraulic oil.

CAUTION

- **Do not use automotive type detergent oil. Detergents will delaminate the motor vanes and cause premature failure.**

■ Air Line Filter

Refer to Dwg. MHP0191

It is recommended that an air line strainer/filter be installed as close as practical to the motor air inlet port to prevent dirt from entering the motor. The strainer/filter should provide 10 micron filtration and include a moisture trap. Clean the strainer/filter monthly to maintain its operating efficiency. Refer to "ACCESSORIES" in the parts section for the recommended Filter-Lubricator-Regulator.

■ Moisture in Air Lines

Moisture that reaches the air motor through the supply lines is the chief factor in determining the length of time between service overhauls. Moisture traps can help to eliminate moisture. Other methods, such as an air receiver which collects moisture before it reaches the motor or, an aftercooler at the compressor that cools the air prior to distribution through the supply lines, are also helpful.

The swivel inlet assembly (includes items 23 through 24C) must be installed on the hoist. Failure to do so may result in a hoist malfunction.

■ Pendant Control Adjustments

The bleed adjustment screws (19) or (336 [old style]) used on hoists with a pendant control are factory adjusted to provide optimum control at 90 psig (6.3 bar/630 kPa) air pressure. If the hoist is used with other air supply pressures, the bleed adjustment screws may require readjustment.

Adjustment Bleed Screw location
(New Style valve chest shown.)

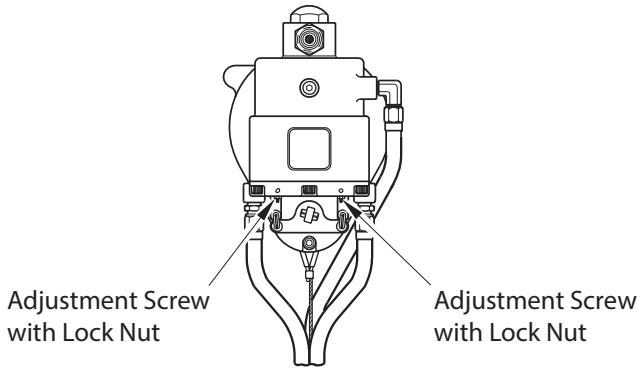

(Dwg. MHP1225)

For maximum performance and control, adjust the bleed screws (19) or (336 [old style]) as follows:

1. Loosen the adjustment screw locknut (21) or (337 [old style]).
2. Turn the adjustment screw (19) or (336 [old style]) counterclockwise approximately one third (1/3) of a turn.

3. Fully depress the pendant throttle lever (165) and hold in depressed position. Turn the adjustment screw clockwise until the piston rod fully retracts. This adjustment will provide a good balance of spotting control and maximum hoist speed. If better spotting control is desired, slowly back out the adjustment screw a little at a time until the spotting control is suitable.
4. When adjustment is complete, hold the adjustment screw in position and tighten the adjustment screw locknut (21) or (337 [old style]).
5. Repeat steps 1 through 4 for opposite pendant throttle lever.

■ **Storing the Hoist**

1. Always store the hoist in a no load condition.
2. Wipe off all dirt and water.
3. Oil the load chain, hook pins and hook latch.
4. Place in a dry location.
5. Plug hoist air inlet port.
6. Before returning hoist to service follow instructions for 'Hoists not in Regular Service' in the "INSPECTION" section.

OPERATION

The four most important aspects of hoist operation are:

1. Follow all safety instructions when operating hoist.
2. Allow only people instructed in safety and operation on this product to operate hoist.
3. Subject each hoist to a regular inspection and maintenance procedure.
4. Be aware of the hoist capacity and weight of load at all times.



- **Do not use this hoist for lifting, supporting or transporting people or lifting or supporting loads over people.**



Operators must be physically competent. Operators should have no health condition which might affect their ability to react, and they must have good hearing, vision and depth perception. The hoist operator must be carefully instructed in his duties and must understand the operation of the hoist, including a study of the manufacturer's literature. The operator must be aware of proper methods of hitching loads and should have a good attitude regarding safety. It is the operator's responsibility to refuse to operate the hoist under unsafe conditions.

■ **Initial Operating Checks**

Hoists are tested for proper operation prior to leaving the factory. Before the hoist is placed into service the following initial operating checks should be performed.

1. After installation of trolley mounted hoists, check to make sure the hoist is centered below the trolley.
2. Check for air leaks in the supply hose and fittings to pendant, and from pendant to manifold.
3. When first running the hoist or trolley motors a small amount of light oil should be injected into the inlet connection to allow good lubrication.
4. When first operating the hoist and trolley it is recommended that the motors be driven slowly in both directions for a few minutes.
5. Operate the trolley along the entire length of the beam.
6. Inspect hoist and trolley performance when raising, moving and lowering test load(s). Hoist and trolley must operate smoothly and at rated specifications prior to being placed in service.
7. Check that trolley (if equipped) and hook movement is the same direction as arrows or information on the pendant control.
8. Raise and lower a light load to check operation of the hoist brake.
9. Check hoist operation by raising and lowering a load equal to the rated capacity of the hoist 4 to 6 inches (100 to 150 mm) off the floor.
10. Check operation of limit devices.
11. Check to see that the hoist is directly over the load. Do not lift the load at an angle (side pull or "yard").
12. Check to see that the hoist is securely connected to the overhead crane, monorail, trolley or supporting member.
13. Check to see that the load is securely inserted in the hook, and that the hook latch is engaged.

! WARNING

- The hook latch is intended to retain loose slings or devices under slack conditions. Hook latches are not intended to be an antifouling device, so caution must be used to prevent the latch from supporting any of the load.

Hoist Controls

Pendant Controls

The HLK hoist can be supplied with an optional manual pull chain control or a one, two or three function pendant depending on application. For detailed information on these products refer to **Ingersoll Rand** Manual Form Number P6778 or contact your nearest distributor or the factory.

Operation of the hoist is the same for all pendants listed in this section:

1. To lift a load, depress the hoist pendant raise lever.
2. To lower a load depress the hoist pendant lower lever.
3. To throttle lift or lowering speed, regulate the amount the pendant lever is depressed. Depress lever completely for maximum speed; depress lever partially for slower speeds.
4. To stop lift or lowering function, release the lever. Lever will spring return to off and hoist motor will stop.

Single Function, Two Lever Pendant

Refer to Dwg. MHP0427.

The two lever pendant is the standard pendant supplied with the HLK and is designed to provide hoist operation only. Hoist operation must correspond to the directions indicated by the arrows located on the pendant levers.

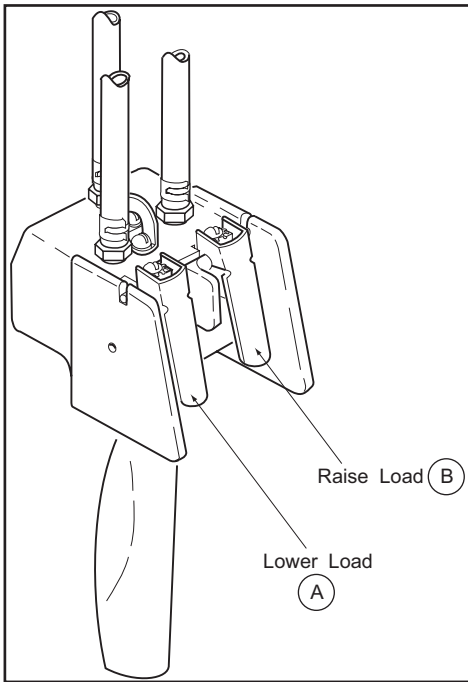

(Dwg. MHP0427)

Two Function, Four Lever Pendant

The four lever pendant is designed to provide a single station for control of hoist and trolley operations.

Refer to Dwg. MHP1008 for pendant lever function and hose to component connections.

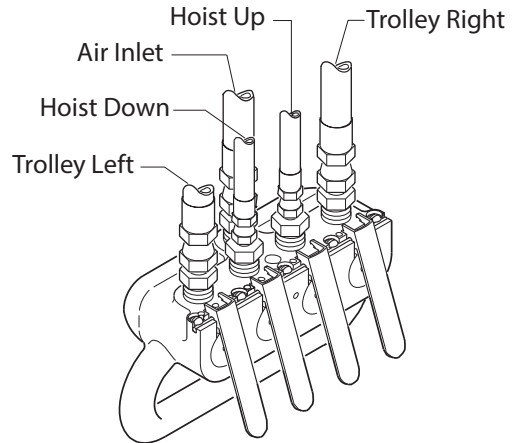

(Dwg. MHP1008)

Three Function, Six Lever Pendant

The six lever pendant is designed to provide a single station for control of hoist and trolley operations.

Refer to Dwg. MHP1009 for pendant lever function and hose to component connections.

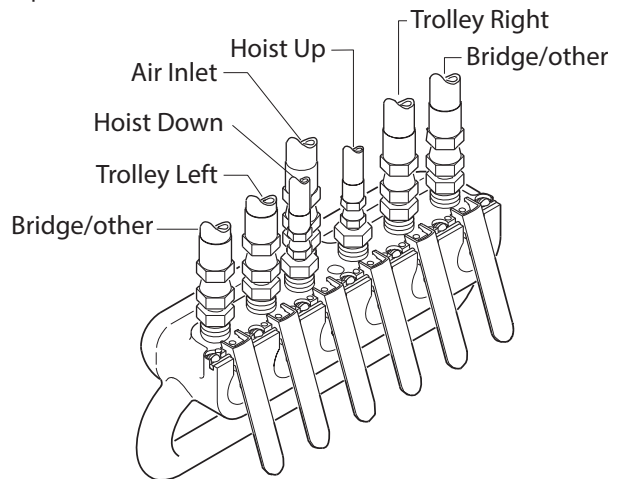

(Dwg. MHP1009)

Pull Chain Control

The pull chain provides the operator with a local hoist operating station. The following operating directions are as viewed from the motor end of hoist, facing the pull chains.

1. To lift a load pull down on the right pull chain.
2. To lower a load pull down on the left pull chain.
3. To throttle lift or lowering speed regulate the distance the pull chain travels. Pull chain to full travel for maximum speed; pull chain partially for slower speeds.
4. To stop lift or lowering of load, release the pull chain. Hoist motor will stop.

INSPECTION

⚠ WARNING

- **All new, altered or modified equipment should be inspected and tested by personnel instructed in safety, operation and maintenance of this equipment to make sure safe operation at rated specifications before placing equipment in service.**
- **Never use a hoist that inspection indicates is damaged.**

Frequent and periodic inspections should be performed on equipment in regular service. Frequent inspections are visual examinations performed by operators or service personnel and include observations made during routine equipment operation. Periodic inspections are thorough inspections conducted by personnel trained in the safety, operation and maintenance of this equipment. ASME B30.16 states inspection intervals depend upon the nature of the critical components of the equipment and the severity of usage.

The inspection intervals recommended in this manual are based on intermittent operation of the hoist eight hours each day, five days per week, in an environment relatively free of dust, moisture and corrosive fumes. If the hoist is operated almost continuously or more than eight hours each day, more frequent inspections will be required.

Careful inspection on a regular basis will reveal potentially dangerous conditions while still in the early stages, allowing corrective action to be taken before the condition becomes dangerous.

Deficiencies revealed through inspection, or noted during operation, must be reported to designated personnel trained in safety, operation and maintenance of this equipment. A determination as to whether a condition constitutes a safety hazard must be decided, and the correction of noted safety hazards accomplished and documented by written report before placing the equipment in service.

■ Records and Reports

Inspection records, listing all points requiring periodic inspection should be maintained for all load bearing equipment. Written reports, based on severity of service, should be made on the condition of critical parts as a method of documenting periodic inspections. These reports should be dated, signed by the person who performed the inspection, and kept on file where they are readily available for review.

■ Load Chain Reports

Records should be maintained documenting the condition of load chain removed from service as part of a long-range load chain inspection program. Accurate records will establish a relationship between visual observations noted during frequent inspections and the actual condition of the load chain as determined by periodic inspection methods.

■ Frequent Inspection

On hoists in continuous service, frequent inspection should be made by operators at the beginning of each shift. In addition, visual inspections should be conducted during regular operation for any damage or evidence of malfunction (such as abnormal noises).

1. **OPERATION:** Check for visual signs or abnormal noises (grinding etc.) which could indicate a potential problem. Make sure controls function properly and return to neutral when released. Check load chain feed through the hoist and bottom block. If chain binds, jumps, is excessively noisy or "clicks", clean and lubricate the chain.

If problem persists, replace the chain. Do not operate the hoist until all problems have been corrected.

2. **HOOKS:** Check for wear or damage, increased throat width, bent shank or twisting of hook. Replace hooks which exceed the throat opening and/or saddle dimension discard widths specified in Table 2 (refer to Dwg. MHP0040) or exceed a 10° twist (refer to Dwg. MHP0111). If the hook latch snaps past the tip of the hook, the hook is sprung and must be replaced. Replace Bullard Burnham hooks if the gate no longer contacts the hook tip. Refer to Dwg. MHP0662. Refer to the latest edition of ASME B30.10 "HOOKS" for additional information. Check hook support bearings for lubrication or damage. Make sure they swivel easily and smoothly.

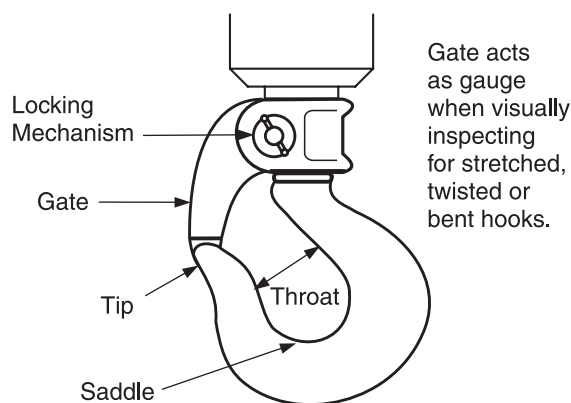

(Dwg. MHP0662)

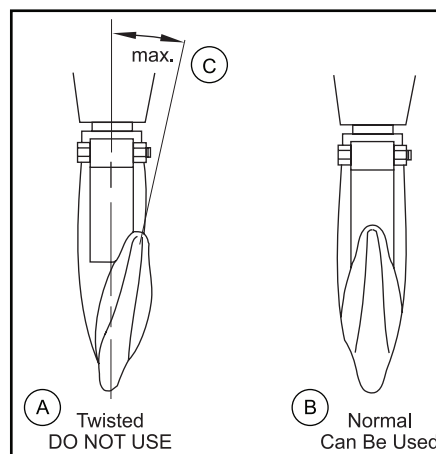

(Dwg. MHP0111)

3. **UPPER AND LOWER LIMIT DEVICE:** Test operation with no load slowly to both extremes of travel. Upward travel must stop when the bottom block or stop ring on chain hits hoist limit arm. Downward travel must stop when the loop at the unloaded end of the chain decreases and activates the limit arm.
4. **AIR SYSTEM:** Visually inspect all connections, fittings, hoses and components for indication of air leaks. Repair any leaks found. Check and clean the filter in the inlet stud (24) and the inlet strainer (24C) if equipped.
5. **CONTROLS:** During operation of hoist, verify response to pendant, or pull chain, is quick and smooth. Make sure that the controls return to neutral and hoist operation stops when released. If hoist responds slowly or movement is unsatisfactory, do not operate hoist until all problems have been corrected.

6. **HOOK LATCH:** Make sure the hook latch or gate is present and operating. Replace if necessary.

CAUTION

- **Do not use hoist if hook latch or gate is missing or damaged.**
- 7. **LOAD CHAIN:** Examine each link for bending, cracks in weld areas or shoulders, traverse nicks and gouges, weld splatter, corrosion pits, striation (minute parallel lines) and chain wear, including bearing surfaces between chain links (refer to Dwg. MHP0102). Replace a chain that fails any of the inspections. Check chain lubrication and lubricate if necessary. Refer to 'Load Chain' in "LUBRICATION" section.

CAUTION

• **The full extent of load chain wear cannot be determined by visual inspection. At any indication of load chain wear inspect chain and chain wheel in accordance with instructions in 'Load Chain' listed in "Periodic Inspection" section.**

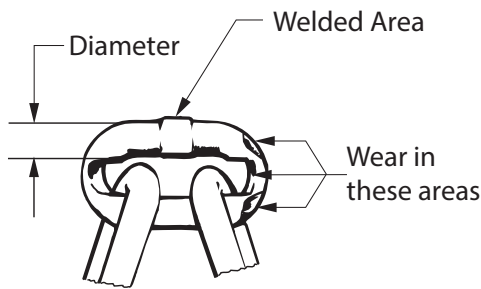

(Dwg. MHP0102)

8. **LOAD CHAIN REEVING:** Make sure welds on standing links are away from the powered chain wheel. Reinstall chain if necessary. On hoists with multiple chain falls, make sure load chain is not capsized, twisted or kinked. Adjust as required.

■ **Periodic Inspection**

Frequency of periodic inspection depends on the severity of

NORMAL	HEAVY	SEVERE
yearly	semiannually	quarterly

Disassembly may be required for HEAVY or SEVERE usage. Keep accumulative written records of periodic inspections to provide a basis for continuing evaluation.

Table 2

Hoist Model	Throat Width (with Latch installed)											
	Standard				Bronze				Bullard Burnham			
	New Hook		Discard Hook		New Hook		Discard Hook		New Hook		Discard Hook	
	in	mm	in	mm	in	mm	in	mm	in	mm	in	mm
HL1000K	1.06	26.9	1.17	29.7	1.36	34.5	1.5	38	1.25	31.8	1.38	35
HL1500K	1.06	26.9	1.17	29.7	1.36	34.5	1.5	38	1.25	31.8	1.38	35
HL2000K	1.38	35	1.52	38.5	1.61	40.9	1.77	44.98	1.50	38.1	1.65	41.9
HL3000K	1.69	43	1.86	47.3					1.88	47.8	2.07	52.6
HL4500K					2.08	52.8	2.29	58.19	3.00	76.2	3.3	83.4
HL6000K	2.09	53.1	2.3	58.4	3.02	76.7	3.32	84.38				

Inspect all the items in "Frequent Inspection". Also inspect the following:

1. **FASTENERS:** Check all rivets, split pins, capscrews and nuts. Replace if missing or tighten if loose.
2. **ALL COMPONENTS:** Inspect for wear, damage, distortion, deformation and cleanliness. If external evidence indicates the need, disassemble. Check gears, shafts, bearings, sheaves, chain guides, springs and covers. Replace worn or damaged parts. Clean, lubricate and reassemble.
3. **HOOKS:** Inspect hooks carefully for cracks using magnetic particle or other suitable nondestructive method. Inspect hook retaining parts. Tighten or repair, if necessary.
4. **LOAD CHAIN WHEELS:** Check for damage or excessive wear. Replace if necessary. Observe the action of the load chain feeding through the hoist. Do not operate a hoist unless the load chain feeds through the hoist and hook block smoothly and without audible clicking or other evidence of binding or malfunctioning.
5. **MOTOR:** If performance is poor, disassemble the motor and check for wear or damage to bearings and shafts. The parts should be cleaned, lubricated and reassembled. Replace worn or damaged parts.
6. **BRAKE:** Raise a load equal to the rated capacity of the hoist 4 to 6 inches (100 to 150 mm) off the floor. Verify hoist holds the load without drift. If drift occurs, disassemble. Remove brake discs as described in the "MAINTENANCE" section. Check and clean the brake parts each time the hoist is disassembled. Replace the brake discs if the thickness is less than 0.090 inch (2.29 mm).
7. **SUPPORTING STRUCTURE:** Check for distortion, wear and continued ability to support load.
8. **TROLLEY** (if equipped): Check that the trolley wheels track the beam properly and clearance between each wheel flange and beam is correct, 3/32 to 1/8 in. (2 to 3 mm). Check that wheels and beam are not excessively worn. Inspect side plates for spreading due to bending. Do not operate the hoist until any problems have been determined and corrected.

- 9. **LABELS AND TAGS:** Check for presence and legibility. Replace if necessary.
- 10. **LOAD CHAIN END ANCHORS:** Make sure both ends of load chain are securely attached. Secure if loose, repair if damaged, replace if missing.
- 11. **LOAD CHAIN:** Measure the load chain for wear over a five link section as shown in Dwg. MHP1291. Pay particular attention to the most frequently reeved links. When any five links in the working length reaches or exceeds the discard length shown in Table 3, replace the entire chain. Always use a genuine **Ingersoll Rand** Material Handling replacement chain.

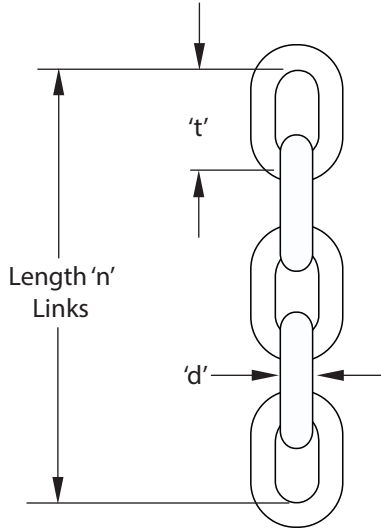

(Dwg. MHP1219)

Table 3 Load Chain Length

Dimensions Of Link		Number Of Links (n)	Discard Length (n) Links
Nominal Wire Diameter (d)	Pitch (t)		
3/8	1.012 in	5	5.161 in
	25.7 mm		131.1 mm

Zinc plated load chain is standard on HLK hoists built after January 1996. Always use stainless steel load chain on HL1000KR Spark Resistant Hoists.

- 12. **CHAIN CONTAINER:** Check for damage or excessive wear and that chain container is securely attached to the hoist. Secure or replace if necessary.
- 13. **LIMIT ASSEMBLY:** Check throttle lever moves freely. To limit hook downward travel the loop in the slack chain side must contact the throttle lever. To limit hook upward travel the bottom hook block, or stop ring, must contact the throttle lever.

To test "UP" and "DOWN" travel limits first run hoist slowly with no load to verify proper function. Repeat test at full speed with no load to verify proper function. On Hoist Models HL4500K and HL6000K the throttle lever (35) may require minor adjustment to provide adequate clearance with the upper suspension block.

■ **Hoists Not in Regular Use**

- 1. A hoist which has been idle for a period of one month or more, but less than one year, should be given an inspection conforming with the requirements of "Frequent Inspection" prior to being placed into service.
- 2. A hoist which has been idle for a period of more than one year should be given an inspection conforming with the requirements of "Periodic Inspection" prior to being placed into service.
- 3. Standby hoists should be inspected at least semiannually in accordance with the requirements of "Frequent Inspection". In abnormal operating conditions hoists should be inspected at shorter intervals.

INSPECTION AND MAINTENANCE REPORT

Ingersoll Rand HLK Air Chain Hoist

Model Number:	Date:
Serial Number:	Inspected by:
Reason for Inspection: (Check Applicable Box)	
1. Scheduled Periodic Inspection: ___ Quarterly ___ Semiannually ___ Yearly 2. Discrepancy(ies) noted during Frequent Inspection 3. Discrepancy(ies) noted during maintenance 4. Other: _____	Operating Environment: ___ Normal ___ Heavy ___ Severe

Refer to the Parts, Operation and Maintenance Manual "INSPECTION" section for general inspection criteria. Refer to appropriate National Standards and Codes of practice. If in doubt about an existing condition contact the nearest Ingersoll-Rand Distributor or the factory for technical assistance.

COMPONENT	CONDITION		CORRECTIVE ACTION		NOTES
	Pass	Fail	Repair	Replace	
Fasteners					
Gears					
Shafts					
Bearings			---		
Load Bearing Sheaves					
Chain Guides					
Springs			---		
Covers					
Hooks:					
Top	Actual Hook Throat Width: _____ inches / _____ mm (Refer to Table 2 for minimum/maximum acceptable widths.)				
	Hook Twist			---	(Maximum 10%)
	Hook Crack Test Method Used: ___ Dye Penetrant ___ Magnetic Particle ___ Other: _____				
Bottom	Actual Hook Throat Width: _____ inches / _____ mm (Refer to Table 2 for minimum/maximum acceptable widths.)				
	Hook Twist			---	(Maximum 10%)
	Hook Crack Test Method Used: ___ Dye Penetrant ___ Magnetic Particle ___ Other: _____				
Hook Latch (Standard)			---		
Hook Gate (Bullard)			---		
Brakes (10% Load Test)			---		
Brakes (Visual Inspection)					
Tail Pin (End Anchor)					
Load Chain:			---		
Working length(s) maximum wear: _____ inches / _____ mm (Refer to Table 3)					
Supporting Structure					
Labels and Tags			---		
Other Components (list in NOTES section)					

Testing:	Pass	Fail	NOTES
Operational (No Load)			
Operational (10% Load)			
Operational (Maximum Test Load *)			

* Refer to the Parts, Operation, and Maintenance Manual 'Load Test' in the "MAINTENANCE" section to determine Maximum Test Load. This page may be photocopied and used by inspectors or maintenance personnel.

LUBRICATION

To make sure continued satisfactory operation of the hoist, all points requiring lubrication must be serviced with the correct lubricant at the proper time interval as indicated for each assembly. Correct lubrication is one of the most important factors in maintaining efficient operation.

The lubrication intervals recommended in this manual are based on intermittent operation of the hoist eight hours each day, five days per week. If the hoist is operated almost continuously, or more than the eight hours each day, more frequent lubrication will be required. The lubricant types and change intervals are based on operation in an environment relatively free of dust, moisture, and corrosive fumes. Use only those lubricants recommended. Other lubricants may affect the performance of the hoist. Approval for the use of other lubricants must be obtained from your **Ingersoll Rand** Technical Support Department or distributor. Failure to provide proper lubrication may result in damage to the hoist and/or its associated components.

INTERVAL	LUBRICATION CHECKS
Start of each shift (Operator)	Check flow and level of air line lubricator (1 to 3 drops per minute) when operating hoist at maximum motor speed.
Weekly (Maintenance personnel)	Clean and lubricate load chain.
	Lubricate hook latch and pivot points.
Monthly (Maintenance personnel)	Inspect and clean or replace air line filter.
Yearly (Maintenance personnel)	Drain and replace housing oil.

Note: Intervals are based on hoist operation in a normal environment as described in the "INSPECTION" section. In HEAVY or SEVERE operating conditions adjust lubrication intervals accordingly.

■ General Lubrication

Whenever a Series HLK Hoist is disassembled for overhaul or replacement of parts, lubricate as follows:

1. Coat all motor parts with a light film of **Ingersoll Rand** Pneu-Lube® Medium Oil No. 50 or a good quality hydraulic oil before assembling.

⚠ CAUTION

- **Do not use automotive type detergent oil. Detergents will delaminate the motor vanes and cause premature failure.**
2. Apply a coating of **Ingersoll Rand** No. 70 Grease or multipurpose grease to the throttle shaft bearings (2) before assembly.
 3. Fill the gear case to the level plug on the side of the housing (1) with **Ingersoll Rand** No. 62 oil, or Texaco Meropa No. 220. Replace oil level plug and vent plug after filling.
 4. The top and bottom hooks are supported by thrust bearings. These bearings must be packed with **Ingersoll Rand** No. 68 grease or a standard No. 2 multipurpose grease at regular intervals. Neglect of proper lubrication will lead to bearing failure.

■ In Line Lubricator

Lubricate the motor with **Ingersoll Rand** Pneu-Lube® Medium Oil No. 10 (or SAE 10), or No. 50 (SAE 20 or 20W) nondetergent motor oil from an in-line lubricator. The use of detergent oil may cause premature failure.

■ Load Chain

⚠ WARNING

- **Failure to maintain clean and well lubricated load chain will result in rapid load chain wear that can lead to chain failure which can cause severe injury, death or substantial property damage.**

1. Lubricate each link of the load chain weekly. Apply new lubricant over existing layer.
2. In severe applications or corrosive environments, lubricate more frequently than normal.
3. Lubricate hook and hook latch pivot points with same lubricant used on the load chain.
4. If required, clean chain with acid free solvent to remove rust or abrasive dust buildup and lubricate the chain.
5. Use **Ingersoll Rand** LUBRI-LINK-GREEN® or a SAE 50 to 90 EP oil.

■ Hook and Suspension Assemblies

1. Lubricate the hook and hook latch pivot points. Hook and latch should swivel/pivot freely.
2. Use **Ingersoll Rand** LUBRI-LINK-GREEN® or a SAE 50 to 90 EP oil.
3. On HL4500K and HL6000K hoists lubricate the idler wheel bearings (107) in the upper suspension housing (101) and lower hook block (123) with **Ingersoll Rand** No. 68 Grease or a good quality No. 2 multipurpose grease.
4. On HL4500K and HL6000K hoists after each 300 hours of operation or more frequently if hoist is operating in a contaminated atmosphere, inject 2 or 3 shots of grease from a grease gun into grease fittings (111) in the end of the idler wheel shafts (110).

■ Housing

Remove the oil level plug from the side of the housing (1). If the oil level is below the tapped hole, remove the vent plug and add a sufficient amount of **Ingersoll-Rand** No. 62 oil (Texaco Meropa No. 3 or Texaco Meropa No. 220). Reinstall the oil level plug and vent plug.

■ Other System Components

Refer to the "LUBRICATION" section in the manufacturer's manual provided with the system component for lubrication requirements.

MAINTENANCE

⚠ WARNING

- **Never perform maintenance on the hoist while it is supporting a load.**
- **Before performing maintenance, tag controls: DANGER - DO NOT OPERATE EQUIPMENT BEING REPAIRED.**
- **Only allow personnel instructed in service and repair of this hoist to perform maintenance.**
- **After performing any maintenance on the hoist, dynamically test hoist to 100% of its rated capacity, in accordance with ASME B30.16 standards, before returning hoist to service. Testing to more than 100% of rated capacity may be required to comply with standards and regulations set forth in areas outside of the USA.**
- **Shut off air system and depressurize air lines before performing any maintenance.**

■ Maintenance Intervals

The maintenance interval chart is based on intermittent operation of the hoist eight hours each day, five days per week, in an environment relatively free of dust, moisture and corrosive fumes. If the hoist is operated almost continuously or more than eight hours each day, more frequent maintenance should be performed.

INTERVAL	MAINTENANCE CHECKS
Start of each shift (Operator or Maintenance Personnel)	Make a thorough visual inspection of the hoist for damage. Do not operate the hoist if damaged.
	Operate the Hoist in both directions. Hoist must operate smoothly without Sticking , binding or abnormal noises. Check the operation of Brake.
Semiannually (Maintenance Personnel)	Inspect the brake. Clean or replace parts as required. Adjust brake as necessary.
Yearly (Maintenance Personnel)	Inspect the hoist gearing, shafts and bearings for wear and damage. Repair or replace as necessary.
	Check all the supporting members, including the suspension, fasteners, nuts, sheaves and rigging, etc. for indications of damage or wear. Repair or replace as required.

■ General Maintenance Instructions

All maintenance work performed on the hoist must be recorded with the date in the inspection report.

Proper use, inspections and maintenance increase the life and usefulness of your **Ingersoll Rand** equipment. During assembly, lubricate gears, nuts, capscrews and all machined threads with applicable lubricants. Use of antiseize compound and/or thread lubricant on capscrew and nut threaded areas prevents corrosion and allows for ease of disassembly of components.

It is recommended that all maintenance work on the hoist be performed on a bench in a clean, dust free work area. During the process of disassembling the hoist, observe the following:

1. Turn off air system and depressurize air lines before performing any maintenance. Disconnect air line from hoist.
2. Never disassemble the hoist any further than is necessary to accomplish the needed repair. A good part can be damaged during the course of disassembly.

3. Never use excessive force when removing parts. Tapping gently around the perimeter of a cover or housing with a soft hammer, for example, is sufficient to break the seal.
4. Do not heat a part with a flame to free it for removal, unless the part being heated is already worn or damaged beyond repair and no additional damage will occur to other parts.

In general, the hoist is designed to permit easy disassembly and assembly. The use of heat or excessive force should not be necessary.

5. Keep the work area clean to prevent dirt and other foreign matter from getting into bearings and other moving parts.
6. All seals, gaskets and O-Rings should be discarded once they have been removed. New seals, gaskets and O-Rings should be used when assembling the hoist.
7. When grasping a part in a vise, always use leather or copper covered vise jaws to protect the surface of the part and help prevent distortion. This is particularly true of threaded members, machined surfaces and housings.
8. Do not remove any part which is press fit in or on a subassembly unless the removal of the part is necessary for repairs or replacement.
9. To avoid damaging bearings during hoist assembly or disassembly always tap or press on the bearing inner race for shaft fit bearings or the outer race for bore fit bearings.
10. If repair work can only be conducted above body height, suitable working platforms or ladders should be made available.

■ Load Chain Care

Keep the chain well lubricated as instructed in the "LUBRICATION" section. Never operate a hoist when the load chain does not flow freely and smoothly into and out of the chain wheel(s), or when it makes noises indicative of binding or other malfunctions.

If the chain is visibly damaged replace the chain and examine the chain wheel and chain guard. Install a new chain wheel if the old one is visibly worn. Install a new guard if the old one is broken or distorted.

Refer to "INSPECTION" section for information on load chain inspection.

⚠ CAUTION

- **The full extent of load chain wear cannot be determined by visual inspection. At any indication of load chain wear inspect chain and chain wheel. Refer to "INSPECTION" section.**

The standard chain provided with this hoist is case hardened to a depth of 0.010 to 0.012 inch (0.25 to 0.35 mm). When the outer hardened case layer is worn through, additional wear will progress rapidly and the strength of the chain will be considerably reduced.

Additionally, the chain will no longer fit the pockets in the hoist chain wheel properly causing the chain wheel to wear rapidly. This will greatly increasing the chance of hoist malfunction and chain breakage.

The hoist chain wheel is designed to outlast several chain replacement cycles if the chain is replaced as recommended.

■ Initial Chain Installation

The following instructions apply to hoists that do not have load chain installed. For hoists with load chain installed, that must be replaced, refer to the 'Chain Replacement' section. When directed to remove or install hoist sections or subassemblies to assist in chain installation, refer to the applicable 'Disassembly' or 'Assembly' section for specific requirements.

■ HL1000K, HL1000KR and HL1500K

The following steps describe the initial installation of chain on single fall hoists that do not have load chain installed.

1. Remove the brake spring and piston housing, brake discs and brake plates to expose the brake driver.
2. From the side of the chain wheel opposite the chain anchor bolt, engage the first link of load chain in a pocket of the chain wheel on edge. Refer to Dwg. TPA706-4, 'Chain Installation - Step 1'. The weld on the load chain link must face away from the powered chain wheel. Refer to Dwg. MHP0472.
3. Rotate the brake driver by hand to feed the load chain through the hoist.

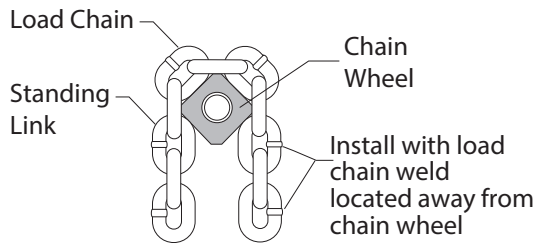

(Dwg. MHP0472)

Chain Installation - Step 1

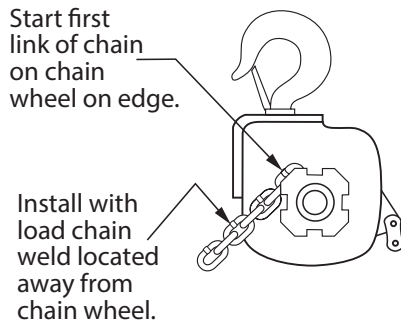

(Dwg. TPA706-4)

4. Keep the load chain straight and do not twist it. Attach the free end of the load chain to the connecting link. Refer to Dwg. TPA706-3, 'Chain Installation - Step 2'. Clean, inspect and install the brake spring, brake discs, brake plates and piston housing on hoist.

Chain Installation - Step 2

5. Attach free end of load chain to hook. Inspect chain while operating hoist slowly. Make sure chain feeds through chain wheel smoothly, without sticking or binding. Repeat operation in the opposite direction.

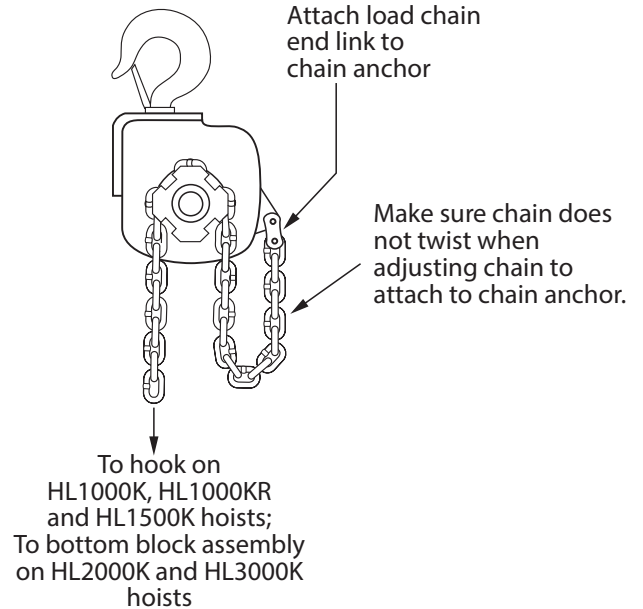

(Dwg. TPA706-3)

■ HL2000K and HL3000K

The following steps describe the initial installation of chain on double fall hoists that do not have load chain installed.

1. Complete steps 1 through 4 of "HL1000K, HL1000KR and HL1500K Chain Installation" section. Refer to MHP0472, TPA706-4, and TPA706-3.

⚠ WARNING

- Replacement chain for an HLK double fall hoist must have an ODD number of total links. Refer to Dwg. MHP0441.

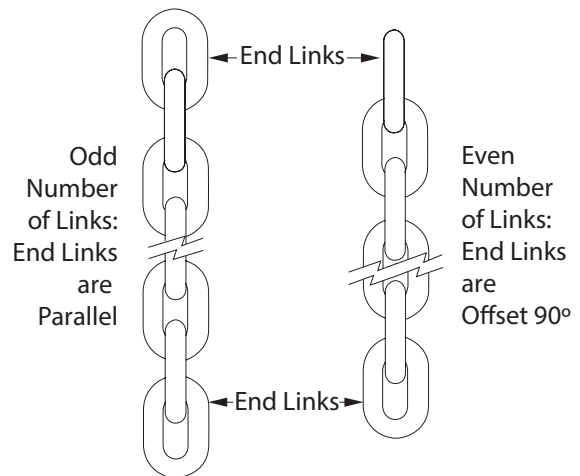

(Dwg. MHP0441)

2. Make sure the chain is straight and feed the end through the bottom hook chain wheel with the first link on edge with the weld to the inside of the idler chain wheel. Refer to Dwg. TPA706-2, 'Chain Installation - Step 3'.

Chain Installation - Step 3

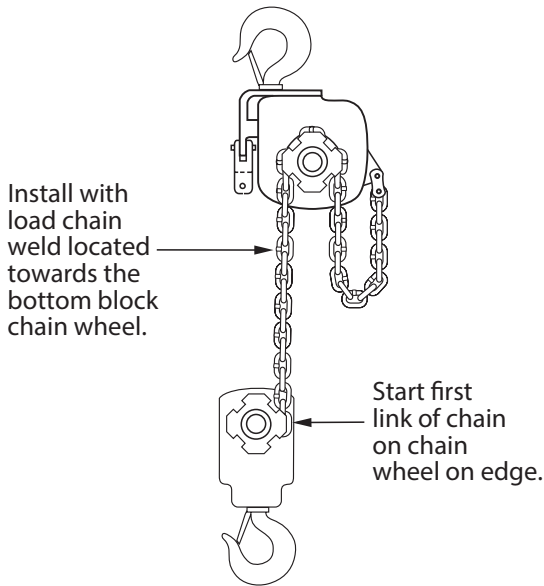

(Dwg. TPA706-2)

3. Make sure the chain is straight and attach the free end to the chain anchor bracket. Refer to Dwg. TPA706-1, 'Chain Installation - Step 4.'

Chain Installation - Step 4

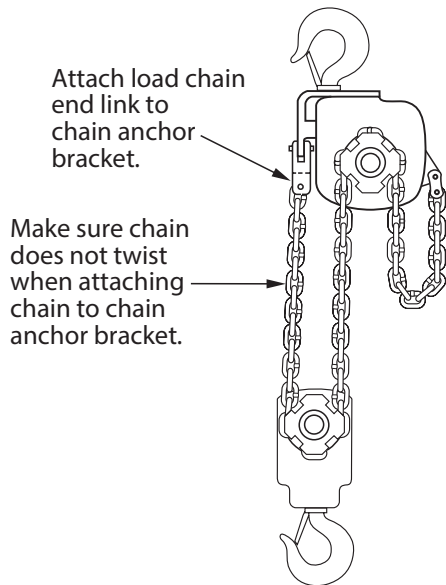

(Dwg. TPA706-1)

4. Inspect to make sure chain is not twisted, kinked or "capsized". Refer to Dwg. MHP0020 and MHP0043.

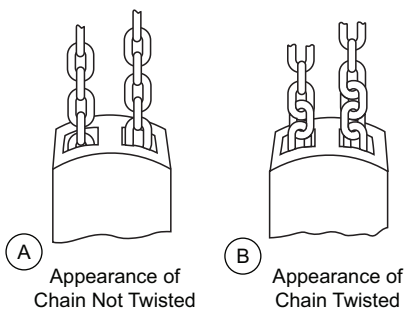

(Dwg. MHP0020)

Capsized Hook

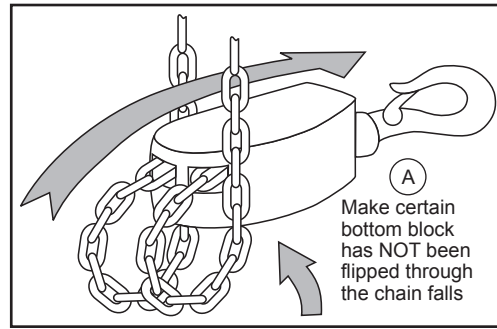

(Dwg. MHP0043)

HL4500K and HL6000K

The following steps describe the initial installation of chain on three or four fall hoists that do not have load chain installed.

1. Remove the brake spring and piston housing, brake discs and brake plates to expose the brake driver.
2. Place the edge of the first link of load chain in a pocket of the hoist powered chain wheel. Refer to Dwg. MHP0472. The weld on the load chain link must face away from the powered chain wheel pocket.

CAUTION

Improper installation of the load chain will cause premature wear of the chain wheels resulting in damaged equipment, which can cause injury or property damage.

3. Rotate the brake driver by hand to feed the load chain through the hoist in the direction of the dead end chain anchor (raise direction).
4. Keep the load chain straight, do not twist it. Attach the free end of the load chain to the connecting link. Refer to Dwg. TPA1056 for HL4500K and Dwg. TPA1057 for HL6000K. Clean and inspect the brake parts and assemble.
5. On HL6000K hoists, slide the limit stop tube onto the load chain.
6. Keeping the load chain straight, complete the load chain installation as described in either the HL4500K or HL6000K 'Hoist Load Chain Reeving' section.

HL4500K Hoist Load Chain Reeving

Refer to Dwg. TPA1056.

After the load chain has been correctly installed onto the hoist powered chain wheel it must be carefully routed through the lower block idler chain wheel, the upper suspension idler chain wheel and secured to the bottom block housing as described in this section.

WARNING

Twisted load chain can jam as it passes over the chain wheel causing damage to the hoist or breaking the load chain which can cause injury or property damage.

1. Raise the bottom hook block to a position near the hoist where it can be properly supported and restrained from movement.
2. Make sure the load chain remains straight. Feed load chain through bottom block idler chain wheel.

NOTICE

- The load chain links that were standing links on the powered chain wheel are also standing links on the bottom block idler chain wheel.
3. Make sure the load chain remains straight. Feed the chain through the upper suspension idler chain wheel.

NOTICE

- The load chain links that were standing links on the powered chain wheel and bottom block chain wheel are flat links on the upper suspension idler chain wheel.

■ **HK4500K Hoist Chain Reeving**

Install load chain with welds placed away from powered chain wheel and upper suspension idler chain wheel

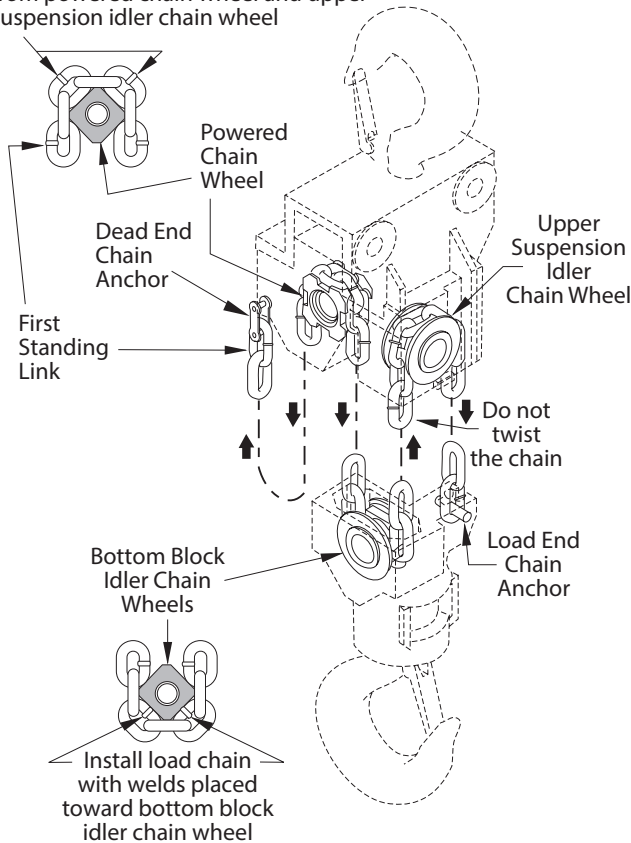

(Dwg. TPA1056)

4. Make sure the load chain remains straight. Feed the load chain through the upper suspension idler chain wheel and insert end link into bottom block load end chain anchor. Do not twist the load chain when attaching it to the load end chain anchor. If necessary cut the last link from the load chain (refer to Dwg. MHP0441) and remove it to prevent twisting. Secure in place using anchor pin.

NOTICE

- The bottom block assembly may require adjustment to make sure it is level with an equal number of load chain links along the length of each load bearing fall. To level out the bottom block assembly feed the load chain through the bottom block and upper suspension idler chain wheels as necessary to 'balance' the bottom block assembly. Make sure the powered chain wheel does not turn during adjustment.

5. Lubricate the load chain as described in the "LUBRICATION" section. Operate the hoist fully in both directions without a load attached. Hoist must operate smoothly without sticking, binding or chain 'jumping'. Test hoist completely as described in the in the 'Testing' section before returning to general service.

■ **HL6000K Hoist Load Chain Reeving**

Refer to Dwg. TPA1057.

After the load chain has been correctly installed onto the hoist powered chain wheel it must be carefully routed through the lower block idler chain wheel, the upper suspension idler chain wheel and secured to the housing as described in this section.

WARNING

- Twisted load chain can jam as it passes over the chain wheel causing damage to the hoist or breaking the load chain which can cause injury or property damage.

1. Raise the bottom hook block to a position near the hoist where it can be properly supported and restrained from movement.

■ **HL6000K Hoist Chain Reeving**

Install load chain with welds placed away from powered chain wheel and upper suspension idler chain wheel

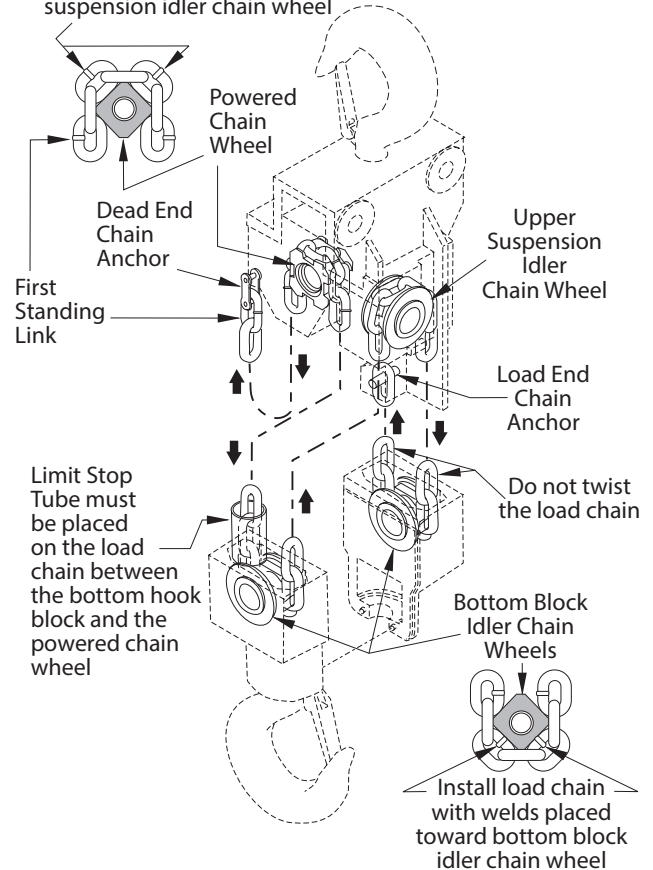

(Dwg. TPA1057)

2. Make sure the load chain remains straight. Place the limit stop tube on the load chain and feed load chain through bottom block idler chain wheel.

NOTICE

- The load chain links that are standing links on the powered chain wheel must also be standing links on the bottom block idler chain wheel.

3. Make sure the load chain remains straight. Feed the chain through the upper suspension idler chain wheel.

NOTICE

- **The load chain links that are standing links on the powered chain wheel and bottom block chain wheel must be flat links on the upper suspension chain wheel.**
4. Make sure the load chain remains straight. Feed the load chain through the second bottom block idler chain wheel. Insert end link into upper suspension load end chain anchor. Do not twist the load chain when attaching it to the load end chain anchor. If necessary cut the last link from the load chain (refer to Dwg. MHP0441) and remove it to prevent twisting. Secure in place using anchor pin.

NOTICE

- **The bottom block assembly may require adjustment to make sure it is level with an equal number of load chain links along the length of each load bearing fall. To level out the bottom block assembly feed the load chain through the bottom block and upper suspension idler chain wheels as necessary to 'balance' the bottom block assembly. Make sure the powered chain wheel does not turn during adjustment.**
5. Lubricate the load chain as described in the "LUBRICATION" section. Operate the hoist fully in both directions without a load attached. Hoist must operate smoothly without sticking, binding or chain 'jumping'. Test hoist completely as described in the 'Testing' section before returning to general service.

■ **Chain Replacement**

The following instructions describe the replacement of load chain on hoists with chain installed. If the load chain has been removed, it must be reinstalled or replaced as described in the 'Initial Chain Installation' section. When directed to remove or install hoist sections or subassemblies to assist in chain installation, refer to the applicable 'Disassembly' or 'Assembly' section for specific requirements.

CAUTION

- **Damaged load chain may cause chain wheel wear or damage and result in hoist failure, injury or property damage. Worn or damaged load chain must be removed, the hoist and bottom block assemblies disassembled and the powered and idler chain wheels inspected before continuing hoist operations.**
- **Do not attempt to replace load chain with hoist supporting a load. Remove all loads.**
- **The following procedures use powered hoist operations. Extreme care must be taken to make sure safe operating conditions exist to prevent injury and hoist or property damage when operating hoist.**

Load chain replacement for all hoist models can be accomplished efficiently and easily by using the existing load chain to install the new load chain.

1. Raise the hoist hook (HL1000K, HL1000KR, HL1500K) or hook block (HL2000K, HL3000K, HL4500K, HL6000K) to a position near the hoist where it can be properly supported and restrained from movement.
2. Disconnect the load chain load end link from either the hook (HL1000K, HL1000KR, HL1500K) or the load end chain anchor (HL2000K, HL3000K, HL4500K, HL6000K). On the HL2000K and HL3000K, remove the load chain from the bottom block.

3. Using an abrasive wheel, cut a section from the end link to form a 'C' link, as shown in Dwg. MHP0502.

CAUTION

- **Do not distort the link in any manner. It must be able to pass over the chain wheel(s) without binding.**

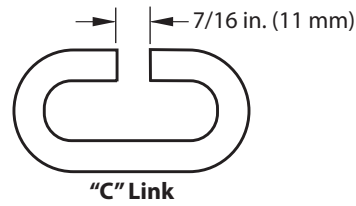

(Dwg. MHP0502)

4. Connect the new chain to the old chain by inserting the end of the new chain onto the 'C' link. Make certain the welds and links on the new chain match the positioning of the welds and links on the chain being replaced.
5. The following hoist specific instructions describe the steps that must be taken to complete the load chain replacement on your hoist.

■ **HL1000K, HL1000KR and HL1500K Chain Replacement**

Complete the initial steps described in 'Chain Replacement'. Conduct the following additional steps on single fall hoists to complete load chain replacement installation.

1. Slowly operate the hoist in the raise direction to run off the old chain and reeve the new chain over the chain wheel. Refer to Dwg. TPA706-4.

NOTICE

- **The first link of new chain over the powered chain wheel must be a standing link.**
2. After the new chain has been reeved over the powered chain wheel, remove the old chain and the 'C' link. Secure the dead end of the load chain to the dead end chain anchor located on the hoist. Refer to Dwg. TPA706-3. Make certain the load chain is not twisted between the chain wheel and dead end chain anchor.
 3. Lubricate the load chain. Refer to "LUBRICATION" section.
 4. Rotate the last link in the load chain such that it is perpendicular to the next link with the weld facing down, towards the hook. Refer to parts Dwg. MHP1105. Attach the hook to the load end of the load chain. Operate the hoist slowly in both directions. Hoist must operate smoothly, without sticking or binding.

■ **HL2000K and HL3000K Chain Replacement**

Complete the initial steps described in 'Chain Replacement'. Conduct the following additional steps on double fall hoists to complete load chain replacement installation.

1. Slowly operate the hoist in the raise direction to run off the old chain and reeve the new chain over the chain wheel. Refer to Dwg. TPA706-4.

NOTICE

- **On double chain fall hoists the total number of load chain links must be an ODD number. Make sure the new load chain has an odd number of total chain lengths. Refer to Dwg. MHP0441.**
- **The first link of new chain over the powered chain wheel must be a standing link.**

2. After the new chain has been reeved over the powered chain wheel, remove the old chain and the 'C' link. Secure the dead end of the load chain to the dead end chain anchor located on the hoist.
Refer to Dwg. TPA706-3. Make certain the load chain is not twisted between the chain wheel and dead end chain anchor.
3. Reeve the load end of the load chain around the bottom block idler chain wheel. Make sure the chain is not twisted between the hoist chain wheel and the bottom block chain wheel.
Refer to Dwg. TPA706-2.
4. Make sure the load chain remains straight and attach the load end of the load chain to the chain anchor bracket located on the hoist.
Refer to Dwg. TPA706-1.
5. Lubricate the load chain. Refer to "LUBRICATION" section.
6. Operate the hoist slowly in both directions. Hoist must operate smoothly, without sticking or binding.

■ HL4500K and HL6000K Chain Replacement

Complete the initial steps described in 'Chain Replacement'. Conduct the following additional steps on three and four fall hoists to complete load chain replacement installation. Refer to Dwg. TPA1056 for HL4500K hoists and TPA1057 for HL6000K hoists.

1. Keeping the new load chain straight, slowly operate the hoist in the raise direction to run off the old load chain and reeve the new load chain over the powered and idler chain wheels.

NOTICE

- **Make certain the welds and links on the new chain match the positioning of the welds and links on the chain being replaced. The new chain must be installed such that as it is reeved through the hoist the first link of new load chain over the powered chain wheel will be a standing link with the weld facing away from the powered chain wheel.**
2. After the new load chain is reeved over the powered chain wheel, remove the old chain from the dead end chain anchor at the side of the hoist and attach the end of the new chain. Make sure the load chain is not twisted between the powered chain wheel and the dead end chain anchor.

WARNING

- **Twisted load chain can jam as it passes over the chain wheels, damaging to the hoist and possibly breaking the chain resulting in injury and property damage.**

3. Keep the load end of the load chain straight, attach the load end link to the load end chain anchor located in the bottom block (HL4500K) or in the upper suspension housing (HL6000K). Do not twist the chain when attaching it to the load end chain anchor. If necessary cut the last link from the load chain and remove it to prevent twisting.
Refer to Dwg. MHP0441.
4. Lubricate the load chain. Refer to the "LUBRICATION" section.
5. Run the hook up and down several times under power with no load to make sure the load chain is running smoothly over the chain wheels. There must be no apparent binding or evidence of malfunctioning.

■ Servicing the Filter and Strainer

1. Disconnect the air supply from the hoist.
2. Unscrew the air hose from the inlet strainer (24C).
3. Unscrew the inlet strainer from the inlet body (23).
4. Clean the screen inside the inlet strainer by washing with a quality, non-toxic, nonflammable commercial solvent in a well ventilated area. If the screen is damaged or cannot be cleaned, replace the inlet strainer.
5. Unscrew the inlet stud (24) from the valve chest (6) and remove the inlet stud and inlet body from the valve chest.
6. Push the inlet stud out of the inlet body.
7. Remove the two swivel inlet seals (24A) from the inlet stud.
8. If the swivel inlet gasket (24B) is damaged, replace it.
9. If hoist is equipped with a filter inside the inlet stud, clean by washing with a quality, non-toxic, nonflammable commercial solvent in a well ventilated area. If the filter cannot be cleaned, replace the inlet stud. (New style inlet studs do not have filters).
10. Moisten the new swivel inlet seals with O-Ring lubricant and install them in the grooves around the body of the inlet stud.
11. Push the inlet stud into the inlet body until the 'hex' of the stud is flush against the face of the inlet body.
12. Keep the threaded hole of the inlet body facing away from the hoist and screw the inlet stud into the valve chest.
13. Screw the inlet strainer into the inlet body.
14. Screw the air hose into the inlet strainer.
15. Reconnect the air supply to the hoist.

Disassembly

WARNING

- **Disconnect the air supply hose before performing any maintenance or repairs on this hoist.**

Refer to 'General Maintenance Instructions' and also note:

1. The HLK hoist is constructed of various modules. During the process of disassembly it is not always necessary to disassemble a particular module just because it is removed from the hoist. For example, the valve chest assembly must be removed (as an assembly) to access and disassemble the motor. However, the valve chest need not be disassembled unless parts within the valve chest require replacement. Do not disassemble the hoist any further than necessary to replace or repair damaged parts.
2. Do not disassemble this hoist unless you have a complete set of new gaskets, O-Rings and seals on hand for replacement. These are available in overhaul gasket kit No. HLK-K445. Idler wheel seals (108) and hook pins (130) are not included in the kit and must be ordered separately.
3. Do not attempt to wash sealed bearings.

New Style Valve Chest Disassembly

This procedure describes the disassembly of valve chests used on hoists with the second letter of the Serial Number other than A through G, or with second and third letters of the Serial Number other than HA, HB or HC. Replacement part numbers are listed in the parts section. Refer to Dwg. TPA958-1.

1. On hoists with pendant control, disconnect the three pendant hoses (171) from the fittings (181) and (182). Remove the valve chest plate screw (30) and disconnect the strain relief cable (175).
2. Remove the pendant links (183).
3. Unscrew the valve chest screws (26) and (27) and remove the valve chest (6) and valve chest gaskets (25).
4. Unscrew and remove the swivel inlet assembly. Push the inlet stud (24) out of the inlet body (23) to expose the swivel inlet seals (24A).
5. Unscrew the valve chest cover screws (22) and remove the valve chest cover (18) and valve chest cover gasket (16).
6. Remove the piston and piston shaft assemblies (14 and 15) and piston springs (13).
7. Remove the valve seat lock screws (11).
8. While exerting pressure against the valve seats (10), use retainer ring pliers to remove the valve seat retainers (12).
9. Using a hooked tool, pull the valve seats from the valve chest or rap the bottom of the valve chest on a block of wood.
10. Remove the valve assemblies (7) and (8) and valve springs (9) from the valve chest.
11. If the piston shaft seals (15A) require replacement, press the piston retaining pins (15B) from each piston and shaft and slide the pistons off the shafts.

Old Style Valve Chest Disassembly

This procedure describes the disassembly of valve chests used on hoists with second letter of the Serial Number A through G or with second and third letters of the Serial Number HA, HB, or HC. Refer to Dwg. TPA883-3.

NOTICE

- **Replacement parts for this valve chest are no longer available. Order kit No. MLK-K545B (03835519) to replace this style valve chest if it cannot be repaired.**

1. On a hoist with pendant control, disconnect the three pendant hoses (171) at the elbows (181) and (182). Remove the valve chest plate screw (30) and disconnect the strain relief cable (175).
2. Unscrew and remove the inlet strainer (24C).
3. Unscrew the valve chest screws (26) and (27) and remove the assembled valve chest and valve chest gaskets (25).
4. Unscrew and remove the swivel inlet assembly. Slide the inlet stud (24) out of inlet body (23) to expose the swivel inlet seal (24A).
5. Unscrew the valve chest cover capscrews (339), and withdraw the valve chest cover (334) along with the piston rods (328) and (329), pistons (330) and piston springs (333). Remove the valve chest cover gasket (338).
6. Withdraw the two valves (325) and the two valve springs (327).

NOTICE

- **Valves (325) and sleeves are manufactured as a matched set. Do not mix valves and sleeves. Make sure the valves are marked for sleeve location at disassembly.**

■ Brake Disassembly

Refer to Dwg. TPB704-3.

1. Unscrew the four shoulder bolts (89) and lockwashers (90) and separate the springs (81) and piston housing (80) as an assembly from the gear case cover (69).

NOTICE

- **When assemblies are separated into component parts the exposed O-Rings and gaskets should be discarded and replaced with new during assembly.**
2. Remove the brake plates (78) and brake discs (79) from the gear case cover. Remove O-Ring (air port) (77) and discard.
 3. Disassemble the spring and piston housing as follows:
 - a. Remove the plate screws (88) and the plate (87).
 - b. Place the assembly, pressure plate (82) downward, on an arbor press, or; place the assembly vertically in a vise.
 - c. While holding the housing against the compression of the springs (81), hold the pressure plate screw (82A) with a wrench and unscrew the piston nut (82B).
 - d. Relax the tension of the compressed springs (81) by slowly and carefully easing up on the arbor press or vise.
 - e. Remove the pressure plate and push the piston (83) from the housing. Remove O-Rings (84) and (85) and discard.
 4. To remove the brake driver (73), remove retainer screw (76) and brake seal retainer (74). Slide brake driver off motor shaft (38). Remove brake seal (75) and discard.

■ Motor Disassembly

Refer to Dwgs. TPA958-1 and TPB703-3.

1. Remove the brake mechanism. Refer to 'Brake Disassembly' section.
2. Drain oil from the gear case.

3. Remove the valve chest (6) as an assembly. Refer to applicable (new or old style) valve chest disassembly section.
4. Remove the limit actuator retaining pin (34) and withdraw the limit actuator (33).
5. Unscrew the remaining valve chest plate screws (30) and remove the valve chest plate (28).
6. Grasp the rear end plate (41) and pull the motor from the hoist as an assembly. If the motor is a little "sticky", tap on the brake end of the motor shaft (38) with a soft drift to loosen.
7. Grasp the motor shaft vertically in copper-covered vise jaws.
8. Remove the motor shaft rear retaining ring (39).
9. Separate the rear end plate (41), rear end plate bearing (40), cylinder (44), cylinder dowel (45), vanes (43), rotor (42), front end plate (46) and front end plate bearing (47) into component parts.

■ Disassembly of the Gearing, Pocket Wheel, Chain Guide, Chain Guard, and Throttle Shaft

Refer to Dwgs. TPB705-2 and MHP1065.

NOTICE

- **When assemblies are separated into component parts the exposed O-Rings and gaskets should be discarded and replaced with new during assembly.**
 1. Remove the brake mechanism. Refer to 'Brake Disassembly' section.
 2. Remove the motor. Refer to 'Motor Disassembly' section.
 3. Remove the four gear case capscrews (70) and lockwashers (71). Remove the gear case cover (69). It may be necessary to use a slide hammer puller attached to a bar and fastened to two of the brake cover bolt holes.
 4. Remove the gear case cover gasket (66) and discard.
 5. If required, separate the fixed ring gear (67) from the gear case cover (69) by gently prying the ring gear from the cover, or by removing the ring gear pins (68). Discard the ring gear pins and replace with new.
 6. Withdraw the planet frame (54) and gears as an assembly. The planet frame may then be disassembled.
 7. Do not remove the needle roller bearings (63A) or (58) from the planet frame or planet gears unless required for repair. If removed they must be discarded and replaced with new sets.
 8. Drive out the throttle lever retaining pin (36) from the throttle shaft (32).
 9. From the motor end of the hoist, withdraw the throttle shaft (32) and remove the throttle lever (35), throttle lever thrust washers (36A) and throttle shaft spring (37).
 10. Withdraw the ring gear (52), powered chain wheel (51A), ring gear bearing (50) and planet frame bearing (63C).
 11. Remove the four chain guide capscrews (4A), lockwashers (4B) and the chain guide (4).
 12. Remove the chain guard (5).

■ Chain Container Disassembly

■ Fabric and Metal Chain Container Disassembly

Refer to Dwg. TPC451-3

1. Run bottom block to lowest point to remove chain from container. Disconnect hoist from air supply.

WARNING

- **Disconnect the hoist from the air supply before removing chain container.**

2. Separate connecting link (91) and remove support chain (306).
3. Remove nuts (303), lockwashers (304) and bracket bolts (302) connecting mounting bracket (301) to hoist.
4. Remove container as an assembly from hoist.
5. If further disassembly is required, refer to Dwg. TPC451-3 to separate the assembly into its component parts.

■ Metal Chain Container HLK-K750-85 Disassembly

Refer to Dwg. 10552230

1. Run bottom block to lowest point to remove chain from container. Disconnect hoist from air supply.

WARNING

- **Disconnect the hoist from the air supply before removing chain container.**
 2. Disconnect short piece of link chain (325) from boss on side of hoist by separating Connecting link (91) and removing link.
 3. Remove self locking nuts (326) and Bracket bolts (324) connecting mounting Bracket (317) to hoist.
 4. Remove container as an assembly from Hoist.
 5. If further disassembly is required, refer to Dwg. 10552230 to separate the assembly into its component parts.

■ Cleaning, Inspection and Repair

Use the following procedures to clean, inspect, and repair the components of the hoist:

■ Cleaning

CAUTION

- **Bearings that are loose, worn or rotate in the housing must be replaced. Failure to observe this precaution will result in additional component damage.**
- **Do not use trichloroethylene to clean parts.**

Clean all hoist component parts in solvent (except for the brake discs). Care must be taken to clean components thoroughly, but not damage components during cleaning. The use of a stiff bristle brush will facilitate the removal of accumulated dirt and sediments on the gears and frames. If bushings have been removed it may be necessary to carefully remove old Loctite® from the bearing bores without damaging the mating surfaces. Dry each part using low pressure, filtered compressed air.

■ Inspection

All disassembled parts should be inspected to determine their fitness for continued use. Pay particular attention to the following:

1. Inspect all gears for worn, cracked, or broken teeth.
2. Inspect all bushings for wear, scoring, or galling.
3. Inspect shafts for ridges caused by wear. If ridges caused by wear are apparent on shafts, replace the shaft.
4. Inspect all threaded items and replace those having damaged threads.
5. Measure the thickness of the brake discs (79). If the brake discs are less than 0.090 in. (2.23 mm) replace the brake discs (79) as a set.
6. Check mufflers (20) and (31) for damage or excessive dirt.
7. Check bearings for rotation and wear. Replace if bearings do not rotate smoothly, without sticking or binding, or if bearings are damaged or excessively worn.

- Inspect brake driver bearing wear area on brake driver (73) and in planet gear frame (54) for ridges or galling. If either condition exists replace parts.

■ Repair

Actual repairs are limited to the removal of small burrs and other minor surface imperfections from gears and shafts. Use a fine stone or emery cloth for this work.

- Worn or damaged parts must be replaced. Refer to the applicable parts listing for specific replacement parts information.

- Inspect all remaining parts for evidence of damage. Replace or repair any part which is in questionable condition. The cost of the part is often minor in comparison with the cost of redoing the job.
- Smooth out minor nicks, burrs, or galled spots on shafts, bores, pins, or bushings.
- Examine all gear teeth carefully, and remove nicks or burrs.
- Polish the edges of all shaft shoulders to remove small nicks which may have been caused during handling.
- Remove all nicks and burrs caused by lockwashers.
- Replace all seals, O-Rings and gaskets.

Assembly

The following assembly instructions are for a complete assembly of the hoist component modules. Conduct those assembly steps necessary to reassemble the hoist from the point of which your disassembly ended. For example: if the brake was removed as an assembly to access the hoist gears, it is not necessary to completely reassemble the brake to reinstall. Conduct only the steps necessary to reattach the brake assembly to the hoist.

■ General Instructions

Refer to 'General Maintenance Instructions' and also:

- The HLK Hoist is constructed of various modules. The following instructions will first describe how to assemble the individual modules and finally, how to assemble a complete hoist from the assembled modules.
- Always press against the stamped end of a needle-type bearing when installing the bearing in a bearing recess.
- Always clean and wipe every part (except the brake parts) with a thin film of oil before installation.
- Never clean sealed bearings using solvent or any other cleaner. Carefully remove dirt, externally applied lubricants and sediment with a rag or stiff bristle brush.

■ Chain Guard Assembly

Refer to Dwg. MHP1065.

- Place the chain guard (5) in housing (1).
- Install the chain guide (4) and loosely secure in place with the chain guide capscrews (4A) and lockwashers (4B).
- When hoist is completely assembled tighten capscrews.

■ Planet Gear Frame Assembly

Refer to Dwg. TPB705-2.

- Press a new planet gear bearing (58) into each end of the planet gears (57). Seat each bearing 1/64 in. (0.5 mm) below the face of the gear.
- Work a liberal amount of **Ingersoll Rand** No. 11 grease into the bore of the planet gear bearings. Make sure each of the individual needles or rollers are thoroughly covered.
- Stand the planet gear frame (54) on the table of an arbor press with its short hub upward.
- Wipe a thin film of **Ingersoll Rand** No. 11 grease on both ends of the planet gears (57) and on the planet gear thrust races (60) and gear thrust bearings (59). Use enough lubricant to allow it to hold the parts in position. Place a planet gear thrust race (60), gear thrust bearing (59) and a second gear thrust race (60) against each face of the planet gear (57).

- Slide the planet gear/thrust races/thrust bearing assembly, with the planet gear large diameter gear teeth located towards the short hub on the planet gear frame, into one side of the planet gear frame. Press in a planet shaft (61) to secure the gear assembly in the gear frame.
- Repeat steps 4 and 5 for the second and third planet gear assemblies.
- Work a liberal amount of **Ingersoll Rand** No. 11 grease into the bore of the brake driver bearing (63A), making certain that each individual needle or roller is covered. Press the brake driver bearing (63A) into the bore of the planet frame (54) hub. Seat bearing 3/16 in. (5 mm) below the face of the hub into the bore of the planet frame (54) hub.
- Install a new brake driver seal (63B) with the lip facing the bearing (63A).
- Place the planet frame retainer (62), planet frame seal (65) and oil slinger (63) on planet frame (54) hub. Install planet frame spacer (64) on hub.
- Make sure the retainer ring is installed on planet frame bearing (63C). Press the bearing fully onto the planet frame (54) hub. Make sure the retainer ring is located with the shortest distance to the edge of the bearing towards the planet frame.
- Position the planet gear frame (54) such that the pinion gear (72A) or (72B) may be installed from the motor side of the planet frame assembly with the brake side accessible for correct timing mark alignment checks.
- Refer to Dwg. MHP0569. Rotate the three planet gears until the "X"s on the ends are all located towards the center of the planet frame (54). The timing marks (•) on the planet gears (57) must locate on the centerline of the outside exposed gear splines.

CAUTION

- It is very important that the Planet gears (57) and Ring gear (52) are correctly aligned when the planet frame assembly is inserted into the Ring gear.**

Planet Gear Timing Mark Arrangement

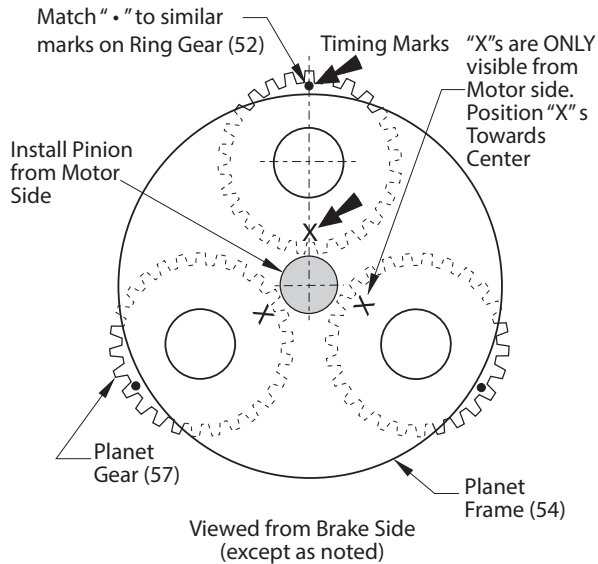

(Dwg. MHP0569)

13. Install the pinion gear (72) with a tooth of the pinion entering each of "X" marked planet gear (57) spaces. The pinion gear internal spline must be located towards the end of the planet frame with the hub (brake end).
14. Make sure the retainer ring is installed on planet frame bearing (56). Place the planet frame spacer (55) on planet frame bearing (56). Install the spacer on the side of the bearing with the most clearance between the retainer ring and the end of the bearing. Press the bearing assembly into the planet frame (54), spacer (55) first, until spacer and retainer ring are flush with the frame.
15. Lubricate and press seal (53) into end of ring gear (52).
16. Lubricate the gear splines and teeth on the planet gears and ring gear (52) with **Ingersoll Rand** No 11 grease. Align the '·' matchmarks on the planet gears (57) to similar '·' matchmarks on ring gear (52) and place the planet frame assembly into the ring gear (52).
17. To install in hoist, refer to 'Hoist Assembly' section.

Motor Assembly

Refer to Dwg. TPB703-3.

1. Grasp the motor shaft (38) vertically in copper-covered vise jaws so that the short-splined end is upward.
2. Press the front end plate bearing (47) into the front end plate (46), and the rear end plate bearing (40) into the rear end plate (41). Apply grease to both bearings.
3. Slide the front end plate and bearing, bearing side first, down over the motor shaft until it seats against the motor shaft shoulder.
4. Slide the rotor (42), counterbored end first, down over the motor shaft until it contacts the front end plate.
5. Moisten each vane (43) with SAE 10 or SAE 20 nondetergent oil, and place a vane in each slot in the rotor (42).
6. Set the cylinder (44) on the rotor, aligning the dowel hole in the cylinder with the dowel hole in the front end plate (46).
7. Slide the rear end plate (41) and bearing (40) assembly, plate flat side first, onto the hub of the motor shaft until it contacts the cylinder. Align the dowel hole in the rear end plate with the dowel hole in the cylinder.
8. Install the motor rear retainer ring (39) in the annular groove on the end of the motor shaft (38).

9. Insert a 1/8 in. (3 mm) steel guide rod about 12 in. (305 mm) long through the dowel holes in the end plates and cylinder to maintain alignment of parts, and remove the assembly from the vise.
10. To install in hoist, refer to 'Hoist Assembly' section.

Brake Assembly

Refer to Dwg. TPB704-3.

1. Lightly coat the piston seals (84) and (85) with O-Ring lubricant, and install them in their respective grooves on the brake piston (83).
2. Taking care not to cut the seals, slide the piston into the brake spring and piston housing (80).
3. Place the spring and piston housing on the workbench with the three spring cavities facing upward.
4. Place a spring (81) in each cavity.
5. **For New Style Pressure Plates (82):** install the pressure plate screw (82A) such that the screw head mates with the counterbore in the pressure plate face. Place the pressure plate (82) and screw over the springs so that the screw enters the hole in the brake piston.

For Old Style Pressure Plates with and Integral Stud:

Install the pressure plate, stud side first, over the springs so that the stud enters the hole in the brake piston.

NOTICE

- **For improved brake control it is recommended that the old style pressure plate be replaced with the new style pressure plate (82) and screw (82A). The old style pressure plate is not available as a replacement part. To replace order Brake Kit No. MLK-ABK1.**
6. Carefully place the assembly in a vise and compress the pressure plate against the brake springs and piston housing until the screw protrudes through the piston. Thread the piston nut (82B) onto the screw at least two full thread lengths, but not enough to fully engage the nut.
 7. Slowly release the assembly from the vise.
 8. **For New Style Pressure Plates:** tighten the pressure plate screw (82A) and piston nut (82B) until a 0.006 to 0.012 in. (0.15 to 0.30 mm) gap exists between the pressure plate and piston. Refer to Dwg. MHP0488.

NOTICE

- **When adjusted, the piston (83) assembly should free float between piston nut (82B) and pressure plate (82). Make sure piston moves freely between nut and pressure plate.**

For Old Style Pressure Plates: torque the piston nut to 50 to 70 inch-lb (6 to 8 Nm).

NOTICE

- **Make sure the piston extends completely through the spring and piston housing and contacts the pressure plate.**
9. Install the plate (87) in the recess of the spring and piston housing (80) and secure using two plate screws (88).
 10. To complete brake installation in hoist, refer to 'Hoist Assembly' section.

Brake Spring and Piston Housing Assembly

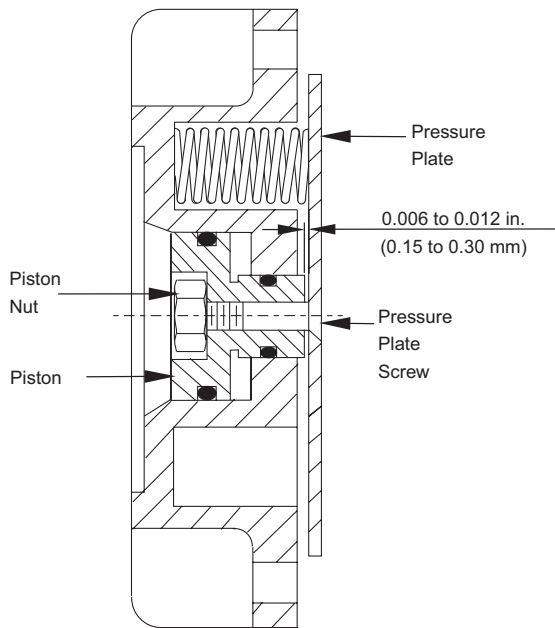

(Dwg. MHP0488)

■ Valve Chest Assembly (New Style)

This procedure describes the assembly of valve chests used on hoists with the second letter of the Serial Number other than A through G, or with second and third letters of the Serial Number other than HA, HB or HC, or hoist valve chests that have been updated with Valve Chest Kit No. MLK-K545B. Replacement part numbers are listed in the Parts section. Refer to Dwg. TPA958-1.

1. If the valve chest cover pins (17) were removed, install them in the bottom of the valve chest (6).
2. Apply a thin film of O-Ring lubricant to the valve seals (7A) and (8A) and install them on the valves (7) and (8).

⚠ CAUTION

- **Do not substitute any other O-Rings for the valve seals.**
3. Install a valve spring (9) on the non-tapered end of each valve and insert the valves, valve spring first, into the openings at the bottom of the valve chest. Make certain the valve marked 'U' is inserted into the opening marked UP VALVE and the valve marked 'D' is inserted in the opening marked DOWN VALVE.
 4. Apply a thin film of O-Ring lubricant to the valve seat shaft seals (10B). Install a seal in each valve seat (10).
 5. Apply a thin film of O-Ring lubricant to the valve seat seals (10A) and install two seals on each valve seat.
 6. Align the smaller diameter crosshole of the valve seat with the threaded hole in the side of the valve chest for the valve seat lock screw (11). With the hub end trailing, install the valve seats in the valve chest.
 7. Screw the valve seat lock screws into the valve chest. Make certain they enter the valve seats. Torque the screws to 24 in lb (3 Nm).
 8. Using retainer ring pliers and applying pressure to the hub of the valve seat, install the valve seat retainers (12). Make certain the retainers seat in the grooves of the valve chest.
 9. If the pistons (14) were separated from the piston shafts (15), apply a thin film of O-Ring lubricant to each piston shaft seal (15A) and install them in the grooves of the piston shafts.

10. Slide the pistons onto the piston shafts with the small hub of the piston toward the smallest diameter of the shaft. Align the crosshole in each piston with the crosshole in each shaft and install the piston retaining pins (15B).
11. Apply a thin film of O-Ring lubricant to the piston seals (14A) and install one on each piston.
12. Apply a thin coat of O-Ring lubricant on the piston cylinder walls and insert the piston springs (13) into the valve chest against the valve seat retainers.
13. Install the assembled pistons and shafts in the valve chest.
14. Apply a thin coat of O-Ring lubricant to the valve chest cover seals (18A) and install them in the valve chest cover (18).
15. Align the valve chest cover gasket (16) with the valve chest cover pins and place the gasket against the valve chest.
16. Align the valve chest cover with the valve chest cover pins and piston shafts and place the cover against the valve chest.
17. Install the six valve chest cover screws (22). Tighten screws evenly and torque to 72 in lb (8 Nm).
18. Thread the adjustment screw locknuts (21) onto the bleed adjustment screws (19) and install the screws in the valve chest cover.

NOTICE

- **Use these screws to adjust hoists with pendant control. Refer to 'Pendant Control Adjustments' in the "INSTALLATION" section.**

19. Manually work the piston shaft assemblies up and down when installed in the valve chest. The piston shafts must shift smoothly with no indication of binding of parts.

■ Valve Chest Assembly (Old Style)

This procedure describes the assembly of valve chests used on hoists with second letter of the Serial Number A through G or with second and third letters of the Serial Number HA, HB, or HC. Refer to Dwg. TPA883-3.

NOTICE

- **Replacement parts for this valve chest are no longer available. Order kit No. MLK-K545B (03835519) to replace this style valve chest if it cannot be repaired. The following assembly instructions are provided for reference only.**

1. Moisten the valve sleeve seals (326) with O-Ring lubricant and install them on the valve sleeves (325).

⚠ CAUTION

- **When installing the valve and valve sleeve assemblies (325), make certain the valves do not get mixed. These are assembled as matched sets.**

NOTICE

- **Each valve sleeve has a notch in one end and a 7/16 inch (11 mm) diameter port in the wall of the sleeve. Inside the valve chest there is a 7/16 inch (11 mm) diameter cross-port that connects the two valve chambers.**
2. Insert the valve sleeves, notched end first, into the valve chest so that the 7/16 in. (11 mm) diameter port in each sleeve is aligned with the cross-port in the valve chest, and so that the notches in the sleeves face each other.
 3. Stand the valve chest up on the inlet port and insert a valve spring (327) and a valve (325) into each valve sleeve. Make certain each valve goes into its proper sleeve. These are matched sets.

4. Moisten each piston seal (331) with O-Ring lubricant and install a seal in the groove on each piston (330).
5. Insert each piston rod (328 and 329), small end first, through its respective hole in the piston.
6. Install a piston nut (332) on each piston rod. Tighten the nut to a snug fit.
7. Moisten the valve chest cover seals (335) with O-Ring lubricant, and install them in the valve chest cover (334).
8. Position the valve chest cover so that the bleed holes and adjustment screws (336) are facing you. Moisten the large diameter of the piston rods with O-Ring lubricant. Insert the longer piston rod (328) through the hole on the left from the gasket side of the valve chest cover. Insert the shorter piston rod (329) through the hole on the right from the gasket side.
9. Place a piston spring (333) in each valve cavity in the valve chest, and position the valve chest cover gasket (338) on the bottom of the valve chest.
10. Taking care not to pinch the piston seals, install the assembled valve chest cover to the bottom of the valve chest. Check to make sure the long stem piston rod (328) is installed in "UP VALVE" side as marked on gasket face of valve chest. Tighten the valve chest cover screws (339) evenly a little at a time until all are tight.
16. If removed, install the fixed ring gear (67) and ring gear pins (68) in the gear case cover.
17. Install the gear case assembly with gasket on the hoist aligning the ring gear roll pins and brake port. Install the four bolts and lockwashers.
18. Install the brake driver (73), brake seal (75), brake seal retainer (74), and brake driver retainer screw (76). Apply a small amount of silicone sealant to O-Ring. The brake driver retainer screw is a self-locking type screw that should be replaced anytime the hoist is disassembled. Torque the screw to 50 in lb (5.65 Nm).
19. Check that the brake driver turns freely by hand. If the brake driver does not turn without restriction in both directions the hoist must be inspected to determine the cause of sticking or binding before further assembly.
20. If removed, assemble the upper suspension. On hook units, inspect the hook and hook latch as described in the "INSPECTION" section. Assemble the latch to the hook. Lubricate the thrust bearing (106).

For HL1000K to HL3000K Hoists:

Assemble the hook (102), thrust bearing (106), thrust washers (107), hook nut (104) and top yoke (101). Be sure to install the roll pin (105) to lock the hook nut on the hook. Mount the top yoke assembly or the lug mount kit to the hoist using lubricated capscrews and locking tabs under the capscrews. Torque the capscrews to 75 - 125 ft lb (100 - 170 Nm). Bend the locking tabs over the capscrews flats to secure.

For HL4500K and HL6000K Hoists:

Lubricate the thrust bearing (131). Assemble the hook (127), thrust bearing, hook nut (129) and upper suspension housing (101). Be sure to install the hook pin (130) to lock the hook nut on the hook. Mount the top yoke assembly or the lug mount kit to the hoist using lubricated capscrews and locking tabs under the capscrews. Torque the capscrews to 75 - 125 ft lb (100 - 170 Nm). Bend the locking tabs over the capscrew flats to secure.

21. Place the throttle shaft spring (37) over the hub of the throttle lever (35) with the bent leg of the spring on the outer side of the throttle lever.
22. Hold the throttle lever in the housing recess beneath the pocket wheel with the bent ends of the lever toward the valve chest end of the hoist and the legs of the throttle shaft spring engaging a rib on the bottom of the chain guide. Insert the throttle shaft (32), round end first, through the valve chest plate, housing and throttle lever. Install a thrust washer (36A) against the hub of the throttle lever. Install a thrust washer (36A) against the throttle shaft spring. Install the throttle lever retaining pin (36).

NOTICE

- **On hoist models HL4500K and HL6000K the throttle lever (35) may require adjustment to provide adequate clearance with the upper suspension block. Minor modifications to the throttle lever are acceptable to establish throttle lever clearance.**

23. Stand the hoist upright on the brake end. Place the valve chest gasket (25) on the valve chest plate, making certain that the small flapper is properly positioned in the recess between the two ports.

■ Assembly of Hoist

1. If removed, install new throttle shaft bearings (2) in the housing and apply a light coating of grease.
2. Install the O-Ring seal (51) in the housing.
3. Install the chain guard (5) in the housing.
4. Install a new oil seal (53) in the output ring gear (52) with the lip facing inward. Coat the lip with a film of oil or grease.
5. Make sure the retainer ring is located on the shaft bearing (50). Install the bearing on the ring gear (52) with the retainer ring end located towards the ring gear.
6. Lubricate the gear splines on the ring gear (52) shaft and the chain wheel (51A) with **Ingersoll Rand** No. 11 grease. Install the chain wheel on ring gear shaft. 7. Install shaft bearing (49) onto the ring gear (52).
8. Install ring gear (52) assembly in housing.
9. Install the chain guide (4), four chain guide capscrews (4A) and lockwashers (4B).
10. Insert the motor retainer washer (48) in the housing. The raised outer diameter should be toward the open/motor end of the housing.
11. Install the motor assembly in the housing by aligning the motor guide rod with the dowel hole in the bottom of the housing and sliding the motor into the housing.
12. Remove the guide rod and replace it with a cylinder dowel (45). Tapered end of dowel pin must enter first. Dowel should be positioned approximately 1/8 in. (3 mm) below the rear end plate (41) surface.
13. Place a housing gasket (3) on the motor end of the hoist and install the valve chest plate (28) and screws (30). Check that motor shaft (38) turns freely by hand without sticking or binding.
14. Note the matchmarks 'v' on the ring gear (52) and on the three planet gears (57). The planet frame assembly must be inserted into the hoist such that the pinion gear (72) internal splines align with the motor shaft (38) splines. Also, the matchmarks 'v' on the planet gears must align with the matchmarks 'v' on the ring gear.
15. Place the gear case gasket (66) on the end of the housing with the gasket hole aligned with the air port.

WARNING

- If the valve chest gasket (25) is installed incorrectly, the small flapper will not be in the recess between the two ports. The brake will not release and may cause damage to the hoist.

24. Center the two round rubber discs in corresponding recesses in the valve chest plate.
25. Place the assembled valve chest (6) on the valve chest gasket. Secure using the valve chest screws (26) and (27).
26. Install hoist load chain as described in the 'Initial Chain Installation' section.
27. Reposition hoist with brake end up. Place a brake plate (78) followed by a brake disc (79), brake plate (78), brake disc (79), and two brake plates (78) over the brake driver (73), aligning the notches in the brake plates with the bolt holes in the gear case cover (69).
28. Reposition hoist with brake end up. Install the assembled brake spring and piston housing (80), making sure the O-Ring (77) is installed at the air port. Install the four shoulder bolts (89) and lockwashers (90).

29. Place the limit actuator (33) on the square end of the throttle shaft, and install the limit actuator retaining pin (34).
30. For new style hoists with second letter of the serial number other than A through G or with second and third letters of the serial number other than HA, HB or HC, install the two pendant links (183) between the limit actuator and the valve shafts.

For old style hoists with pendant control with second letter of the serial number A through G or with second and third letters of the serial number HA, HB or HC, install a pendant link (183) between the limit actuator and the long piston rod.

For old style hoists with pull chain control with second letter of the serial number A through G or with second and third letters of the serial number HA, HB or HC, no pendant links are required.

31. Apply a thin film of O-Ring lubricant to the swivel inlet seals (24A). Install seals on inlet stud (24) grooves.
32. Carefully push the inlet stud into the inlet body (23). Take care to prevent cutting seals.
33. Apply a thin film of O-Ring lubricant to the swivel inlet gasket (24B). Install the gasket on the inlet stud.
34. Thread the inlet assembly into the top of the valve chest and tighten.
35. Fill gear case with oil per instructions in lubrication section.

Pendant Installation

Refer to Dwg. TPA0882-3.

CAUTION

- Disconnect the hoist from the air supply before performing maintenance on this hoist.

When installing a pendant assembly on HLK Hoists, a crimping tool (Part No. ML50K-930AT or a Nicopress® Tool with Groove Size G) must be used to install the clamping sleeve (176) on the ends of the strain relief cable (175).

The strain relief cable (175) must be long enough to allow the pendant hose to hang nearly straight yet short enough to absorb the pendant weight and forces.

CAUTION

- Make sure the strain relief cable supports the pendant. Do not allow the pendant hoses support the weight of the pendant. Hose failure can cause injury and loss of hoist control.

NOTICE

- When the control hoses are cut to length, the hose at the back of the pendant (air in) should extend 6 in. (150 mm) beyond the top clamping thimble.

Depending upon which valve chest is used on the hoist, the length of the two hoses at the front of the handle will vary.

1. On the new style MLK-A545A valve chest, the hoses should extend 2 in (51 mm) beyond the top clamping thimble (177). Refer to Dwg. TPB767.
2. On the old style MLK-A545 valve chest, the hoses should extend 4 in (100 mm) beyond the top clamping thimble (177). Refer to Dwg. TPB766.
3. Install one hose tie (218) above the pendant handle (160) and one hose tie below the clamping thimble (177). Install the remaining hose ties every 2-1/2 feet (0.76 m) between the hose ties at the handle and thimble.
4. Install the warning tag such that the tag can be read by the operator from the lever side of the pendant handle.

New Style Valve Chest Connections

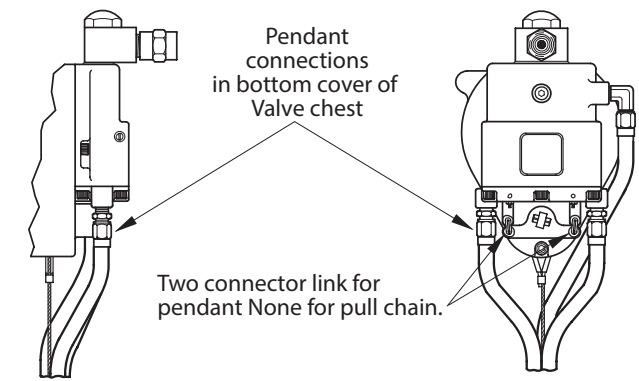

(Dwg. TPB767)

Old Style Valve Chest Connections

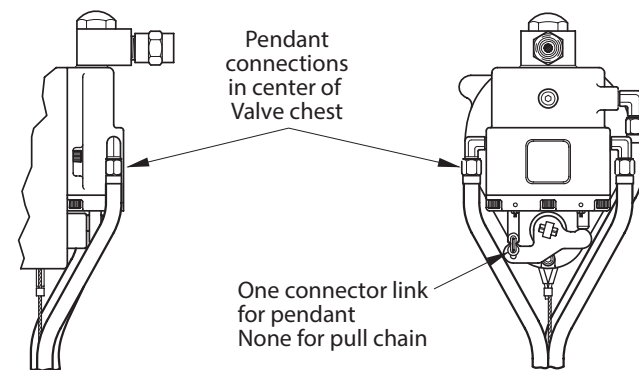

(Dwg. TPB766)

Chain Container

To Install Fabric and Metal Chain Container

Refer to Dwg. TPC451-3

1. Position the mounting bracket (301) between the bosses at the bottom of the hoist in the area of the chain opening.

2. Insert two bracket bolts (302) from the inside of the chain container, through the mounting bracket and bosses. The bracket bolt heads should contact the mounting bracket.
3. Place a washer (304) and bracket nut (303) on each bracket bolt.

NOTICE

- **If the container is to be allowed to swing outward, tighten the bracket nuts (303) to within one turn of being fully tight. This will allow the container to swing away from a load.**
4. Because of space limitations, it may be necessary to depress the throttle lever (35) to install the bracket bolts (302) on hoists equipped with a hand chain throttle. Hoists equipped with a pendant throttle may require removal of the pendant links (183) to install the bracket bolts. Reinstall the pendant links after the mounting bracket is attached to the hoist.
 5. Fasten the support bracket (305) to the outside of the chain container with the bracket nut and washer located to the outside of the chain container.
 6. Fasten the chain container to the mounting bracket in the same manner.
 7. Carefully disassemble the chain anchor (91) and attach one end of the support chain (306) onto the chain anchor with the load chain (92).

CAUTION

- **Make certain the load chain does not become twisted when attaching the support chain to the chain anchor.**
8. Fasten the free end of the support chain to the support bracket with the support bracket bolt (307), support bracket washer (309) and the support bracket nut (308).

NOTICE

- **Adjust the support chain at the support bracket to prevent the load chain from rubbing against the container when operating the hoist.**

To Install Metal Chain Container HLK-K750-85

Refer to Dwg. 10552230

The following instructions are for adding the HLK-K750-85 metal chain container kit to a standard hoist.

1. Run bottom block to lowest point to provide access to the installation area on the hoist. Disconnect hoist from air supply.

WARNING

- **Disconnect the hoist from the air supply before installing chain container.**
2. Position the chain container (318) between the bosses at the bottom of the hoist in the area of the chain opening. Attach Bracket (317) to hoist body. Insert two Bracket Bolts (324) from the inside of the chain container, through the mounting bracket and bosses. The bracket bolt heads should contact the mounting bracket. Install self locking nuts (326) on bolts.
 3. Attach short piece of Link Chain (325) to boss on side of hoist using Link (91).
 4. Attach Chain Stop assembly (319) near end of load chain. See HLK-K750-85 Chain Stop Placement illustration.

5. Check for proper operation of Control Lever.

HLK-K750-85 Chain Stop Placement

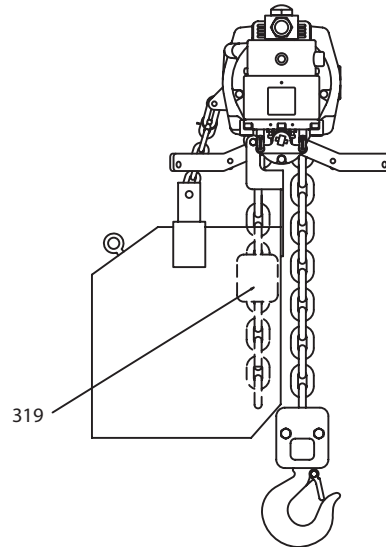

MHP4303

NOTICE

- **Operate the hoist to naturally pile chain into the chain container. Piling the chain carelessly into the container by hand may lead to kinking or twisting that may cause chain to jam the hoist.**
6. Tighten all screws. Provide supply air to hoist, and run chain into container.

Load Test

Prior to initial use, all new, extensively repaired, or altered hoists shall be load tested by or under the direction of personnel instructed in safety, maintenance and operation of this hoist. A written report must be maintained on record confirming the rating of the hoist.

1. Operate the hoist fully in both directions without a load. Hoist must operate smoothly, without evidence of binding. Response to operating controls must be quick and accurate.
2. Place a 10% load on hoist and operate hoist fully in both directions. Hoist must operate smoothly, without evidence of binding. Response to operating controls must be quick and accurate.
3. Dynamically load test hoist to 100% of its rated capacity. Hoist must operate smoothly, without evidence of binding. Response to operating controls must be quick and accurate.

NOTICE

- **Testing to more than 100% may be necessary to comply with standards and regulations set forth in areas outside of the USA.**

TROUBLESHOOTING

This section provides basic troubleshooting information. Specific causes to problems are best identified by thorough inspections performed by personnel instructed in safety, operation and maintenance of this equipment. The chart below provides a brief guide to common hoist symptoms, probable causes, and remedies.





SYMPTOM	CAUSE	REMEDY
Hoist will not operate.	No air supply to hoist, or too little flow or pressure.	Check air supply line connections and hoses. Check supply air at hoist motor inlet. A minimum of 70 scfm (1.96 cu. m/m) air flow at 90 psig (6.3 bar/630 kPa) at hoist motor inlet is required to provide rated performance.
	Hoist is overloaded.	Reduce load to within rated capacity.
	Motor is damaged.	Disassemble, inspect and replace parts. Refer to "MAINTENANCE" section.
	Pendant malfunction.	Check pendant throttle lever for free movement. Check air pressure at pendant. Minimum operating pressure in pendant line must be 55 psig (3.8 bar/380 kPa). Check lubricator oil level. Fill if low.
	Brake not releasing.	Check brake release circuit and pressure. Minimum operating pressure at brake inlet must be 55 psig (3.8 bar/380 kPa).
Load continues to move when hoist is stopped (UP direction).	Valve or throttle lever sticking.	Check pendant throttle lever for free movement. Lubricate or repair as required.
	Dump valves not releasing.	Check pendant hose dump valves.
	Pendant lever sticking.	Check pendant throttle lever for free movement.
Load continues to move when hoist is stopped (DOWN direction).	Dump valves not releasing.	Check pendant hose dump valves.
	Dump valves not releasing.	Check pendant hose dump valves.
	Hoist is overloaded.	Reduce load to within rated capacity.
	Valve or throttle lever sticking.	Check pendant throttle lever for free movement.
	Brake is slipping.	Check brake springs and brake disc linings for wear. Refer to "MAINTENANCE" section.
Hoist does not lift load.	No air supply to hoist, or too little flow or pressure.	Check air supply line connections and hoses. Check supply air at hoist motor inlet. A minimum of 70 scfm (1.96 cu. m/m) air flow at 90 psig (6.3 bar/630 kPa) at hoist motor inlet is required to provide rated performance.
	Hoist is overloaded.	Reduce load to within rated capacity.
	Main air travel is restricted.	Check throttle lever and linkage for free, unobstructed movement.
	Exhaust restricted.	Inspect vents and replace mufflers. Refer to "MAINTENANCE" section.
	Motor is damaged.	Disassemble, inspect and replace parts. Refer to "MAINTENANCE" section.
Reduced speed and/or capacity.	Inlet stud (24) screen plugged, restricting air flow.	Replace old style inlet stud with screen with new style (without screen), or remove screen.
	Lubricator oil level low.	Fill lubricator.
	No air supply to hoist, or too little flow or pressure.	Check air supply line connections and hoses. Check supply air at hoist motor inlet. A minimum of 70 scfm (1.96 cu. m/m) air flow at 90 psig (6.3 bar/630 kPa) at hoist motor inlet is required to provide rated performance. Check pendant control adjustment as described in the "INSTALLATION" section.
	Bleed screws out of adjustment.	Adjust bleed screws as described in 'Bleed Screw Adjustment' procedure in "INSTALLATION" section.
Hoist operates in LOWER direction but will not LIFT.	Hoist is overloaded.	Reduce load to within rated capacity.
	Pendant malfunction.	Check pendant throttle lever for free movement. Check air pressure at pendant. Minimum operating pressure in pendant line must be 55 psig (3.8 bar/380 kPa).
Hoist operates in LIFT direction but will not LOWER.	Brake piston seals leaking.	Install new seals. Refer to "MAINTENANCE" section.
	No air supply to hoist, or too little flow or pressure.	Check air supply line connections and hoses. Check supply air at hoist motor inlet. A minimum of 70 scfm (1.96 cu. m/m) air flow at 90 psig (6.3 bar/630 kPa) at hoist motor inlet is required to provide rated performance.
Load chain jumps on sheave or makes a "snapping" sound.	Dirty or lack of oil on load chain.	Clean and lubricate load chain. Refer to "LUBRICATION" section.
	Worn or rusted load chain.	Inspect load chain. Refer to "INSPECTION" section. Clean and lubricate load chain. Refer to "LUBRICATION" section.
	Worn load sheave or incorrectly reeved load chain.	Check load chain is correctly reeved. Disassemble, inspect and replace worn parts. Refer to "MAINTENANCE" section.
	Capsized hook.	Correct as described in "MAINTENANCE" section.
	Hoist not in-line with load.	Align hoist with load. Do not side pull or "yard".

安全信息

本手册为所有相关人员提供有关本产品的安全安装、操作以及正确维护的重要信息。即使您认为自己已经非常熟悉此设备或相似设备，也应在操作前阅读本手册。

■ 危险、警告、小心和注意

本手册中有些步骤和程序，如果不严格遵守可能导致危险。下列词汇用于确定潜在危险程度。

	危险	即将发生的危险情况，若不可避免，则会导致严重的伤害或死亡。
	警告	潜在的危险情况，若不可避免，则将导致严重的伤害或死亡。
	小心	潜在的危险情况，若不可避免，则将导致轻微或中度的伤害或财产损失。
	注意	与人身安全或财产安全直接或间接有关联的信息及公司政策。

■ 安全信息

警告

- 请勿将该起重机或附接的设备用于起吊、支撑或运送人员或在人员上方支撑载荷。
- 动力驱动的起重机设计为提供 5 到 1 安全系数。结合该起重机使用的支撑结构以及载荷附接设备必须提供充分的支撑，以处理所有起重机操作以及起重机和附接设备的重量。这是客户的责任。如果有任何疑问，请咨询注册结构工程师。

注意

- 不同国家对提升和操作设备的规定也不尽相同。这些规定可能未在本手册中出现。

国家安全委员会工业操作事故预防手册 (Accident Prevention Manual for Industrial Operations) 第八版以及其它安全规定都有一个共同点：在悬挂载荷附近工作、帮助吊装和安排载荷的员工都应避免站立在载荷的正下方。从安全的角度而言，有一个方面是至关重要的：所有的提升操作都应遵循一条原则，那就是万一设备出现故障，不会有任何人员会因此受伤。这就要求所有人员不能位于提升重物的下方，并远离任何重物作用力的范围。

Ingersoll Rand 材料搬运卷扬机是根据最新的 ASME B30.16 标准制造的

1970 职业安全与健康法案 (Occupational Safety and Health Act of 1970) 将相关责任赋予所有者/雇主，而非制造商。许多 OSHA 要求与制造的产品无关，但却与最终的安装紧密相连。确定产品是否符合任何特定的用途，这是所有者和用户的责任。建议查询所有适用的行业、贸易协会、联邦、州和当地法律法规。操作前应阅读所有操作说明和警告信息。

索具：操作人员应自己注意操作的安全性，使用常识进行判断，并掌握正确的传动技术。有关索具的信息，请参阅 ASME B30.9，American National Standards Institute, 1430 Broadway, New York, NY 10018。

本手册由 Ingersoll Rand 制作，为经销商、机械师、操作人员和公司员工提供有关产品安装、操作、维护和维修的信息。

机械师和操作人员必须熟悉这些产品或类似产品的维修程序，并且能够亲身执行这些程序，这一点非常重要。这些人员应该具备常规的工作知识，包括：

1. 常用机械手动工具以及特定 Ingersoll Rand 或推荐工具的正确与安全使用。
2. 由公认行业标准确立的安全程序、预防措施和工作习惯。

Ingersoll Rand 无法知道需要采取何种产品操作和维修方法以及每种方法的危险和/或结果，也无法提供全部的程序。如果进行非制造商特定推荐的操作和维修程序，则必须确保采取的行动不会危及产品的安全性。如果对某个操作或维修程序或步骤不确定，相关人员应将产品置于安全的环境中，并联系监督人员和/或 Ingersoll Rand 提供技术帮助。

安全操作说明

以下警告和操作说明改编自美国国家（安全）标准，旨在避免可能导致伤害或财产损坏的不安全操作行为。

Ingersoll Rand 了解到大多数使用起重机的公司对其设备的操作都有一套完整的安全程序。如果您发现本手册中的某项条例与某公司既定的类似条例存在冲突，则应该优先考虑两者中较为严格的规定。

另外安全操作说明还提醒操作人员要避免的危险操作，并且不局限于以下列表。有关其它安全信息，请参考本手册中的相应章节。

1. 只有接受过此产品安全和操作指导的人员才能操作和维护起重机。
2. 只能在身体条件合适的情况下操作起重机。
3. 如果起重机控件上带有“DO NOT OPERATE”（请勿操作）标志，在指定人员揭下该标志之前，请勿操作起重机。
4. 在操作起重机之前，请阅读制造商的操作说明。
5. 切勿起吊大于起重机额定容量的载荷（除非是为了进行测试）。
6. 切勿将载重链用作吊绳。
7. 切勿使用扭曲、打结、“倾覆”或损坏的链条操作起重机。
8. 务必确保载荷物正确固定在吊钩的凹处。
9. 请勿将载重链用作焊接底面。请勿将焊接电极连接到起重机或吊链。
10. 请勿将上、下止挡用作停止起重机的装置。上和下止挡仅为紧急装置。
11. 请勿长时间将载荷悬挂。
12. 不得站在载荷路径上。

13. 切勿将起重机用来起吊或降下人员，切勿站立在悬挂载荷上。
14. 严禁在人员上方搬运载荷。
15. 每个班次前，请检查起重机是否存在磨损和损坏状况。检查制动器、限位止挡等。
16. 定期彻底检查起重机并更换磨损或损坏的部件。
17. 按照润滑说明操作。
18. 请勿尝试维修载荷链或吊钩。在它们磨损或损坏时进行更换。
19. 如果载荷链未在钩下方对中，切勿操作起重机。请勿从一侧拉动载荷物或“堆砌”载荷物。
20. 务必正确、小心地操作起重机。
21. 在开始起吊时，让载荷链绷紧。严禁猛拉起重机电荷。
22. 让载荷链保持洁净并且润滑良好。请勿在地板上拖动载荷链或钩子。
23. 确保移动载荷的路径上没有物体。
24. 在对起重机进行任何维护前，务必切断气源。
25. 请勿使悬挂载荷摆动。
26. 当不使用时，让载荷块位于头顶上方。
27. 在使用后，或者在非工作模式下，应当锁定绞车，防止未经授权和没有保障地使用。
28. 避免起重机受到磕碰。
29. 在操作起重机时，始终注意起重机电荷。
30. 切勿通过在链节之间插入螺栓或其他任何装置来接合起重机电荷。
31. 请勿用锤子将链条或钩子敲入，切勿将链节作为钩吊点。
32. 请勿让链条暴露在极冷天气下。请勿将载荷施加至温度过低的链。

规格

表 1

起重机型号	额定能力 (kg)	下垂链条数量	额定载荷下的速度				一半载荷下的速度				没有载荷下的速度				起重机重量*	
			fpm		m/m		fpm		m/m		fpm		m/m			
	向上		向下	向上	向下	向上	向下	向上	向下	向上	向下	向上	向下	lb	kgs	
HL1000K	1000	1	26	37	7.9	11.3	31	30	9.4	9.1	40	26	12.2	7.9	84	38.1
HL1000KR			16	26	4.9	7.9	22	22	6.7	6.7	28	16	8.5	4.9		
HL1500K	1500	2	13	18	4.0	5.5	15	15	4.6	4.6	20	13	6.1	4.0	125	56.6
HL2000K	2000		8	13	2.4	4.0	11	11	3.4	3.4	14	8	4.3	2.4	129	58.5
HL3000K	3000		4.6	10	1.4	3.0	7.5	8.4	2.3	2.6	10.5	6.6	3.2	2.0	193	87.5
HL4500K	4500	3	3.5	7.6	1.0	2.3	5.8	6.2	1.8	1.9	8.4	4.8	2.6	1.5	248	112.5
HL6000K	6000	4														

注意：

* 基于安装了钩的标准起吊距离为 10 ft (3 m) 的起重机，并且具有一个马达控制板。

** 性能数据基于 70 SCFM (1.96 cu m/min)，起重机入口处的气源为 90 psig (6.3 bar/630 kPa)。控制板型号使用大约 4 SCFM (0.11 cu m/min) 或更多的空气。

型号代码说明:

范例:	HL1000K-2C10-C6S	H	L	1000K	-	2	C	10	-	C	6	S
系列:	=	H										S
链条类型:		L										S
	L =	链节										S
基本型号:				1000K								S
	1000K =			1000K = 1000 kg 1 公吨 (2,200 lb)								S
	1000KR =			1000KR = 1000 kg 1 公吨 (2,200 lb) 防火花								S
	1500K =			1500K = 1500 kg 1-1/2 公吨 (3,300 lb)								S
	2000K =			2000K = 2000 kg 2 公吨 (4,400 lb)								S
	3000K =			3000K = 3000 kg 3 公吨 (6,600 lb)								S
	4500K =			4500K = 4500 kg 4-1/2 公吨 (10,000 lb)								S
	6000K =			6000K = 6000 kg 6 公吨 (13,200 lb)								S
控件:												S
	0 =			未提供控件								S
	1 =			拉动链								S
	2 =			单马达悬架								S
	3 =			二马达悬架								S
	4 =			三马达悬架								S
悬架 (1):												S
	A =			固定安装耳								S
	B =			Bullard 钩 (半闭合)								S
	C =			旋转钢质弹簧扣								S
	R =			铜质弹簧扣								S
	DA =			纯刚性吊车 (通用轮 "A" 法兰)								S
	DD =			纯刚性吊车 (通用轮 "D" 法兰)								S
	FXXA (2) =			手动操作吊车 (通用轮 "A" 法兰)								S
	FXXD (2) =			手动操作吊车 (通用轮 "D" 法兰)								S
	HA =			叶片马达提供动力的吊车 (通用轮 "A" 法兰)								S
	HD =			叶片马达提供动力的吊车 (通用轮 "D" 法兰)								S
起吊长度:												S
	10 =			10 英尺 (3 米) 标准								S
	XX =			指定长度								S
下方钩:												S
	B =			Bullard 钩 (半闭合)								S
	C =			钢质弹簧扣								S
	R =			铜质弹簧扣								S
拉动链的长度或控制板软管下降距离: *												S
	6 =			6 英尺 (1.8 米) 标准								S
	XX =			指定长度 (以英尺为单位)								S
选项:												S
	M =			手动释放制动器套件								S
	P =			通过管道排放								S
	S =			钢质链条箱								S
	U =			纤维链条箱								S

1. XX = 指定所需的手动链长度。范例: "08" = 8 英寸, 标准。
2. 以英尺为单位订购软管长度。列出公制尺寸仅供参考。

安装起重机之前，请仔细检查是否有运输导致的损坏。起重机出厂时就已经进行了所有必需的润滑。建议在首次进行起重机操作之前润滑负载链条。

小心

- 建议机器所有者和用户在安装起重机或将其投入使用之前，研究可能适用于本产品特定类型用途的特定本地法规或其它法规，其中包括“美国国家标准学会”标准和/或“美国健康和安生署”法规。

警告

- 负荷跌落可能导致伤害或死亡。在安装之前，请阅读“安全信息”。
- 结合该起重机使用的支撑结构以及载荷附接设备必须提供充分的支撑，以处理所有起重机操作以及起重机和附接设备的重量。这是客户的责任。如果有任何疑问，请咨询注册结构工程师。

起重机检查

确保起重机正确安装。额外花一点时间做这些事可以防止事故，帮助您获得可以获得的最好服务。务必确保悬挂起重机的支撑组件有足够的强度来支撑起重机自身重量加最大额定负载量，再考虑到自由安全系数。

小心

- 在对起重机进行维修之前，从加油孔拆下方头管道塞，并替换为附有提醒标记 CA210-121 的六角头通气孔塞。
- 将位于起重机顶部的实心装运塞拆下，并安装附送的通气孔塞，然后再开始使用起重机。
 - 在起重机置于正常水平位置的情况下，检查齿轮箱油位是否在齿轮箱侧的检查塞上。

起重机安装

吊钩安装式起重机安装

将吊钩放在安装结构的上方。确保吊钩足够大，可在结构上正确适配。确保吊钩栓锁入到位。确保支撑组件完全在此吊钩的鞍座内，并且在吊钩杆正上方的正中位置。起重机必须自由悬挂在吊钩上，不会受到约束。

小心

- 支撑组件必须位于吊钩的凹处。确保起重机不会倾斜至一侧或另一侧。

吊车安装式起重机安装

请参阅图MHP0866。

在一根梁上安装吊车，测量此梁的法兰，然后暂时在起重机上安装此吊车，以确定垫圈的正确分布和排列情况。轮缘之间的总距离应当比梁翼的宽度大 3/16 至 1/4 英寸（5 至 6 mm）。起重机上吊车侧板和安装耳之间的垫圈数量必须与四个位置中的数量相同，才能保证起重机位于 I 型梁下方的正中位置。剩余的垫圈必须平均分布在吊车侧板外部。

注意

- 有关吊车安装的具体信息，请参阅吊车随附的制造商手册。

HLK 起重机纯刚性吊车

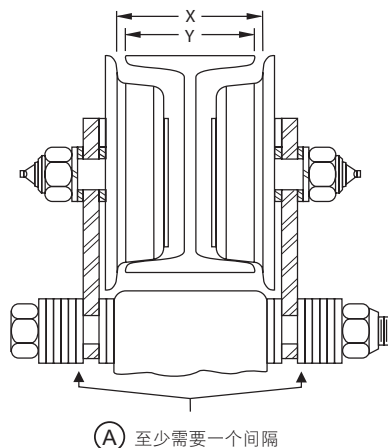

(图MHP0866)

注意：确保 $X-Y=3/16$ 至 $1/4$ 英寸（5 至 6 mm）

警告

- 必须将至少一个调节垫片置于吊车侧板的外部。确保按照吊车随附的部件、操作和维护手册中的说明正确安装。

吊车螺栓螺母 (207) 和 (220) 扭矩要求：

在 HL1000K、HL1500K、HL2000K 和 HL3000K 起重机上，扭矩达到 150 ft lb (203 Nm)。

在 HL4500K 和 HL6000K 起重机上，扭矩达到 250 ft lb (339 Nm)。在 HL4500K 和 HL6000K 起重机上，扭矩达到 250 ft lb (339 Nm)。

在梁上安装起重机和吊车时，请确保侧板平行和垂直。在安装之后，在整个梁长度上方操作吊车，带有距离地面 4 至 6 英寸（100 至 150 mm）的悬挂额定载荷。

小心

- 要避免不平衡的载荷导致损坏吊车，起重机必须位于吊车下方的正中位置。

注意

- 吊车滑轮位于梁的低位法兰顶部。

确保梁止挡已安装，然后再操作起重机和吊车。

链条箱

请参阅图TPC451-3 和 MHP4303 以及“维护”一节了解详细的装配和拆卸信息。

注意

- 确保调整箱支撑，使链条箱不与载荷链接触。
- 操作起重机以自然地将链条堆放到链条箱中。用手不当地将链条堆放到箱中可能导致打结和扭曲，从而可能导致链条卡住起重机。

- 检查链条箱尺寸，以确保载重链长度没有超过链条箱的容积长度。如果需要，可以用更大号链条箱。
- 将链条箱连接到起重机。
- 将底部块移动到最低点，然后向上移动起重机，以将链条送回链条箱。

警告

- 将起重机与气源断开，然后再安装链条箱套件。

■ 空气系统

气源必须洁净、经过润滑并且不含水或湿气。在起重机马达入口，至少需要 70 scfm (1.96 cu. m/m)、90 psig (6.3 bar/630 kPa) 的气源，以在操作期间提供额定的起重机性能。

■ 供气

当气源和起重机之间的距离在 12 ft (4 m) 以内时，起重机气源管路的内径不得小于 1/2 in (13 mm)，当距离在 50 ft (15 m) 以内时，不得小于 3/4 in (19 mm)。当距离大于 50 ft (15 m) 时，有关建议的空气管路尺寸，请联系厂家。在进行最后连接之前，必须使用没有湿气的干净空气吹扫所有供气管，然后才能连接到装置进气口。在安装条件允许范围内，供气管应尽可能短且直。由于管线中存在限制和表面摩擦，较长的传输管线和过多使用接头、弯头、T 型头、球阀等部件会降低压力。用在起重机入口处的接头必须具有至少 3/8 in (10 mm) 的空气通道。使用更小的接头将降低性能。

注意

- 务必将空气管路过滤器和润滑器用于 HLK 起重机。

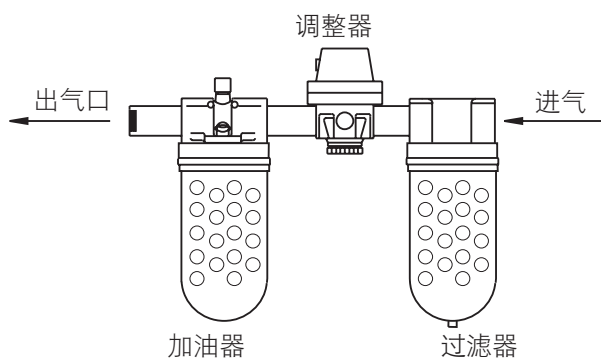

(图MHP0191)

■ 供气润滑器

请参阅图MHP0191。

须使用这些起重机随带的气管加油器。润滑器的入口和出口至少必须与起重机马达上的入口一样大。将空气管路润滑器安装在尽可能靠近起重机马达上的进气口位置。有关建议的过滤器-润滑器-调节器组合，请参阅部件部分中的“附件”。

⚠ 小心

- 润滑装置必须在离起重机马达 10 英尺 (3 米) 距离范围之内。
- 在对供气润滑装置注油之前，请关闭气源。

空气管路润滑器应当每日重新装满并设置为在最大起重机速度下以每分钟 1 至 3 滴的最小速率提供润滑，并使用 SAE 10W 油或优良等级的液压油。

⚠ 小心

- 请勿使用汽车用洗涤剂。洗涤剂将会让马达叶片脱层，导致永久性故障。

■ 供气过滤器

请参阅图MHP0191

建议在允许的情况下，尽可能靠近马达空气入口安装空气管路滤网/过滤器，以防止尘垢进入马达。滤网/过滤器应该提供 10 微米过滤能力，还包括一个除湿器。每月清洁滤网/过滤器，以维持其运行效率。有关建议的过滤器-润滑器-调节器组合，请参阅部件部分中的“附件”。

■ 供气管中的湿气

通过供气管到达气马达的湿气是决定维修检查时间间隔长短的主要因素。除湿器有助于消除湿气。也可使用其他方法，如空气接收箱（可在湿气到达马达之前收集湿气）或压缩机上的二次冷却器（在通过供气管传输空气之前冷却空气）。

必须在起重机上安装旋转入口组件（包括项目 23 至 24C）。否则可能导致起重机故障。

■ 控制板调节

在带控制板的起重机上使用的减压调节螺钉 (19) 或 (336 [旧式]) 在出厂时经过调节，以在 90 psig (6.3 bar/630 kPa) 的空气压力下提供最佳控制。如果将起重机搭配其他气源压力使用，可能需要重新调节减压调节螺钉。

调节减压螺钉位置

(示出了新式阀门室。)

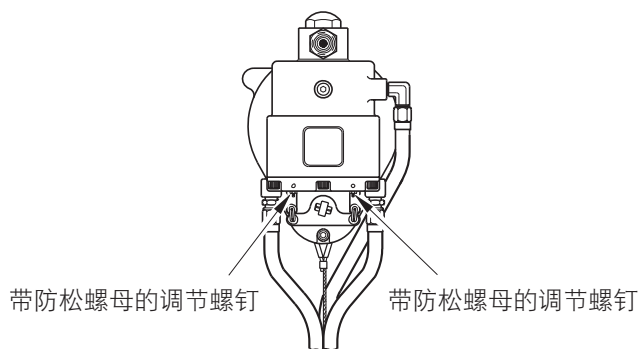

(图MHP1225)

为了实现最大性能和最佳控制，如下调节减压螺钉 (19) 或 (336 [旧式])：

1. 松开调节螺钉防松螺母 (21) 或 (337 [旧式])。
2. 将调节螺钉 (19) 或 (336 [旧式]) 逆时针转动大约三分之一 (1/3) 圈。
3. 完全压下悬垂节流阀杆 (165) 并保持在压下位置。顺时针转动调节螺钉，直至活塞杆完全拆下。该调节将提供合模控制和最大起重机速度的良好平衡。如果需要更佳的控制，一次性缓慢地稍微退出调节螺钉，直至合模控制达到适宜程度。
4. 当调节完成时，将调节螺钉保持在位置上，并紧固调节螺钉防松螺母 (21) 或 (337 [旧式])。
5. 对于相对的悬垂节流阀杆，重复步骤 1 至 4。

■ 存放起重机

1. 务必在无载荷的情况下存放起重机。
2. 擦干净所有的灰尘和积水。
3. 对载荷链条、吊钩销和吊钩栓涂油。
4. 存放在干燥位置。
5. 堵塞起重机进气口。
6. 重新使用起重机之前，请按照“检查”部分中的“非常规使用的起重机”说明操作。

操作

起重机操作的四个最重要方面是：

1. 操作起重机时必须遵守全部安全说明。
2. 只允许接受过本起重机安全和操作指导的人员操作起重机。
3. 每部起重机必须具有定期检查和维修程序。
4. 任何时候都要知道起重机的负载能力和负载重量。

警告

- 请勿将该起重机用于起吊、支撑或运送人员或在人员上方支撑载荷。



操作人员的身体状况必须符合要求。操作人员不应当有可能影响其反应能力的健康问题，并且他们必须具备良好的听力、视觉和深度感知能力。起重机操作人员必须经过全面的责任和义务指导，必须了解起重机的操作规程，包括阅读制造商提供的相关说明。操作人员必须全面掌握连接载荷的正确方法，并认真对待安全问题。操作人员有责任拒绝在不安全的条件下操作起重机。

■ 初始操作检查

起重机在出厂前已通过正常操作的测试。在将起重机投入使用之前，必须先进行下列初始操作检查。

1. 在安装吊车安装式起重机后，进行检查，确保起重机在吊车下方居中。
2. 检查控制板的供应软管和接头中是否存在空气泄漏，以及从控制板到歧管之间是否存在空气泄漏。
3. 首次运转起重机或吊车马达时，需要在输入接头中注入少量轻油，从而起到充分润滑的作用。
4. 首次操作起重机或吊车时，建议在两个方向缓慢转动马达并运行几分钟。
5. 沿整个梁长度操作吊车。
6. 在起吊、移动和放下测试负载物时检查起重机和吊车的性能。投入使用之前，起重机和吊车必须运行顺畅、处于额定规格。
7. 检查吊车（如果配备）和吊钩移动是否和箭头的方向一样，或者是否和控制板上的信息一致。
8. 升起并降下轻型负载以检查起重机制动器的操作。
9. 通过从地面升起和降下等同于起重机额定容量的负载物 4 到 6 英寸（100 到 150 mm）来检查起重机操作。
10. 检查限制设备的操作。
11. 进行检查，确定起重机是否在载荷的正上方。请勿成角度起吊载荷（侧面拉动或“堆砌”）。

12. 进行检查，确保起重机牢固连接在高架起重机、单轨道、吊车或支撑构件上。
13. 进行检查，确保负载物牢固地插入吊钩，并且吊钩栓锁锁入到位。

警告

- 吊钩栓锁用于控制松弛的吊索或处于松弛状态的装置。吊钩栓锁并未设计成防污装置，因此必须小心，防止栓锁支撑任何载荷。

■ 起重机控制

■ 控制板

HLK 起重机可附带选配的手动拉动链控件，或一个、两个或三个功能控制板，具体取决于应用。有关这些产品的详细信息，请参阅 Ingersoll Rand 手册表格编号 P6778 或联系离您最近的经销商或工厂。

起重机的操作对于本部分中所列的所有控制板相同：

1. 要起吊载荷，压下起重机控制板起吊杆。
2. 要降下载荷，压下起重机控制板下降杆。
3. 要调节起吊或降下速度，可调节压下的控制板杆的量。完全压下杆可达到最大速度；部分压下杆可减慢速度。
4. 要停止起吊或降下功能，请释放杆。杆将回复至关闭位置，并且起重机马达将停止。

■ 单个功能，两杆控制板

请参阅图MHP0427。

两杆控制板是 HLK 随附的标准控制板，旨在仅提供起重机操作。起重机操作必须和控制板杆上的箭头指示的方向对应。

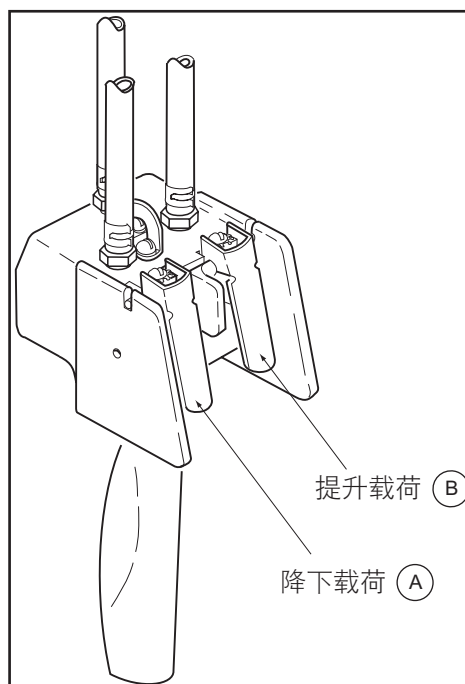

(图MHP0427)

■ 两个功能，四杆控制板

四杆控制板旨在提供单个站，用于控制起重机和吊车操作。请参阅图MHP1008，了解控制板杆功能以及组件连接的软管。

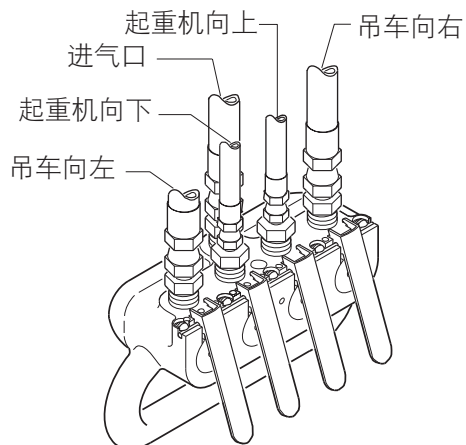

(图MHP1008)

■ 三个功能，六杆控制板

六杆控制板旨在提供单个站，用于控制起重机和吊车操作。请参阅图MHP1009，了解控制板杆功能以及组件连接的软管。

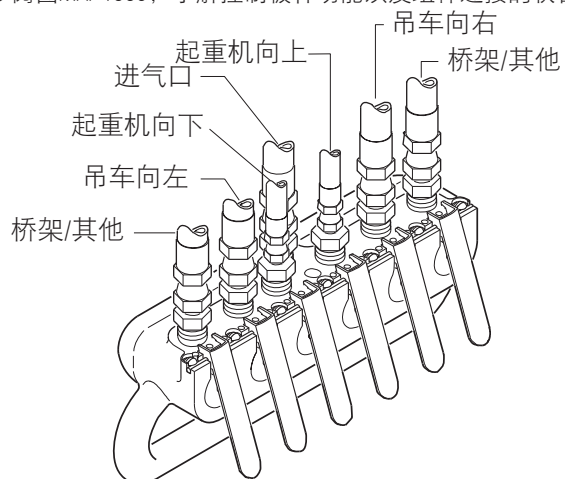

(图MHP1009)

■ 拉动链控制

拉动链可为操作人员提供一个本地起重机操作站。以下操作方向是面向拉动链（从起重机的马达端的视角方向）。

1. 要起吊负载，请向下拉右拉动链。
2. 要降下负载，请向下拉左拉动链。
3. 要调节起吊或降下速度，可调节拉动链行进的距离。拉动链至满行程可达到最大速度，部分拉动链可减慢速度。
4. 要停止载荷的起吊或降下，请释放拉动链。起重机马达将停止。

警告

- 应当由在设备安全、操作和维护上接受过指导的人，对全新、经过改动、改造的设备进行检查和测试，以确保以额定规格进行安全操作，然后再将设备投入使用。
- 切勿使用检查中指出有损坏的起重机。

应该对正常使用中的设备进行经常性和定期检查。经常性检查是由操作人员或维修人员执行的目视检查，包括在常规设备运行期间的观察。定期检查由在本设备的安全、操作和维护上经过培训的人员执行。ASME B30.16 指出，检查时间间隔应根据设备的关键组件的材质和使用度而定。

本手册中建议的检查间隔基于起重机一周五天、每天八小时的间歇操作，工作环境相对无尘、无湿气、无腐蚀性烟气。如果起重机几乎是连续运行，或每天的运行时间超过 8 小时，则需要更频繁地进行检查。

定期进行仔细检查能够发现仍存在于早期阶段的潜在危险情况，并在此危险情况变成真正危险之前采取更正措施。

通过检查或在操作期间发现的缺陷必须报告给在本设备的安全、操作和维护上经过培训的指定人员。对于某种状况是否构成安全危险，必须做出判定；在将设备投入使用之前必须纠正所发现的安全危险情况，并以书面报告形式加以记录。

记录和报告

应为所有承载设备保留罗列所有要求定期检查的部位的检查记录。根据维修的严重程度编制的书面报告应反映关键零件的状况，并将其作为记录定期检查的一种方法。这些报告应注明日期、由执行检查的人员签字，并存放在随时可以审查的文件夹中。

载重链报告

应该维护用于记录在维修中卸下的载重链情况的报告，作为长期载荷链条检查计划的一部分。准确的记录可确定在经常性检查期间进行的目视观察和定期检查方式确定的载重链的实际情况之间的关系。

经常性检查

对于连续运行的起重机，应在每个班次开始时由操作人员执行经常性检查。此外，定期操作期间还应进行目视检查，以发现任何损坏或故障迹象（诸如异常噪声）。

1. **操作：**检查是否出现指示潜在问题的可视迹象或异常噪音（碾磨声等）。确保控制功能在释放状态下正常工作并且可返回到空档。检查载荷链是否穿过起重机和底部块。如果链条被卡住、跳动、噪音过大或发出“卡嗒声”，请对链条进行清洁和涂上润滑油。如果问题继续存在，请更换链条。在更正所有问题之前，请勿操作起重机。
2. **吊钩：**检查是否有磨损或损坏、挂钩喉部宽度增大、挂钩杆弯曲或扭曲。更换超出表 2 中指定的喉部开口和/或凹处尺寸废弃宽度（参考图MHP0040）的吊钩或超出 10° 扭曲（参考图MHP0111）的吊钩。如果吊钩栓锁与挂钩尖端咬合过头，挂钩将会弹出，必须将其更换。如果关口和吊钩尖端不再接触，则更换 Bullard Burnham 吊钩。请参阅图MHP0662。有关其他信息，请参阅最新版本的 ASME B30.10 “挂钩”。检查吊钩支撑轴承是否润滑或存在损坏。确保它们能够轻松无阻地回转。

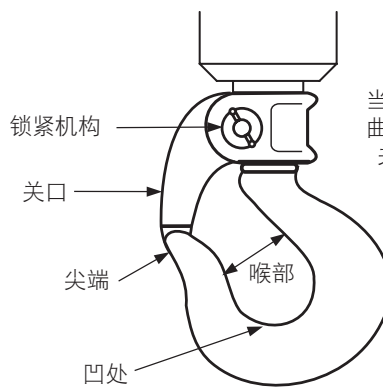

当目视检查拉伸、扭曲或弯曲的吊钩时，关口用作计量器。

(图MHP0662)

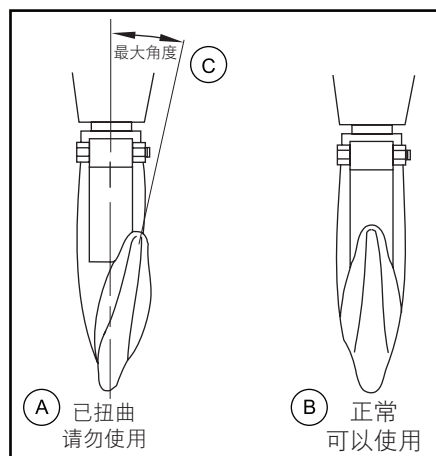

(图MHP0111)

3. **上和下限位装置：**在无负载情况下，测试操作可以按两个行程方向尽头慢慢进行。如果链条上的底部块或止挡块碰到起重机限位臂，则必须停止向上行进。如果链条卸载端的回路减小则必须停止向下行进，并启动限位臂。
4. **空气系统：**目视检查所有连接、接头、软管和部件是否有空气泄漏迹象。维修发现的任何泄漏。检查并清洁入口螺栓 (24) 和入口滤网 (24C) (如果配备) 的过滤器。
5. **控件：**在起重机的操作期间，检查控制板、拉动链的操作是否迅速而顺畅。在释放之后，确保控件回到空档位置，并且起重机操作停止。如果起重机响应缓慢，或移动情况不满意，则在更正所有问题之前，不要操作起重机。
6. **吊钩栓锁：**确保吊钩栓锁或关口存在并且正常工作。如有必要，请予以更换。

小心

- 如果吊钩栓锁或关口缺少或损坏，请勿使用起重机。

7. **载荷链：**检查每个链节是否出现弯曲，焊接区是否有裂纹、凸起、横向凹痕以及凿孔、焊渣、蚀坑、条纹（细小的平行线）和链条磨损，包括链节之间的轴承表面（请参考图MHP0102）。更换检查中发现任何问题的链条。检查链条润滑情况，并根据需要进行润滑。请参见“润滑”部分下面的“载荷链条”。

小心

- 目视检查无法确定所有的载荷链条损坏。只要出现任何载荷链条磨损迹象，就应该根据“定期检查”部分中所列的“载荷链条”中的说明检查链条和链轮。

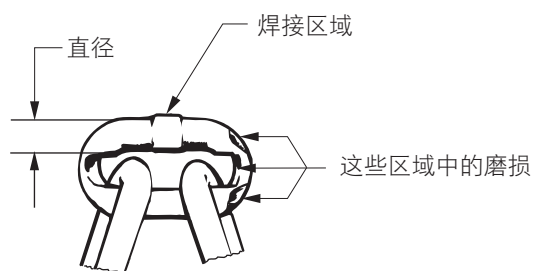

(图MHP0102)

8. **载荷链穿接**: 确保固定链节上的焊接远离动力驱动的链轮。如果有必要, 重新安装链条。在具有多根下垂链条的起重机上, 确保载荷链没有翻转、扭曲或缠绕。根据需要进行调整。

■ 定期检查

根据以下严重程度经常或定期检查

一般	重度	严重
每年	每半年	每季度

对于“重度”或“严重”使用情况, 可能需要拆卸。保留定期检查的累积性书面记录, 以对持续评估提供依据。

检查“经常性检查”中的所有项目。另外检查以下方面:

- 紧固件**: 检查所有铆钉、开口销、有头螺钉和螺母。
如果缺失则进行更换, 如果松动则进行紧固。
- 所有组件**: 检查是否出现磨损、损坏、扭曲、变形以及是否清洁。如果外部迹象表明需要, 则进行拆卸。检查齿轮、轴、轴承、绞缆轮、链条导板、弹簧和护盖。更换磨损或损坏的部件。清洁、润滑和重新装配。

- 吊钩**: 使用磁性微粒或其他合适的非破坏性方法, 仔细检查吊钩是否有裂纹。检查吊钩固定部件。根据需要进行紧固或维修。
- 载荷链轮**: 检查是否有损坏或过度磨损。如有必要, 请予以更换。观察通过起重机进给的载荷链的操作。除非载荷链可以顺畅穿过起重机和挂钩组并且没有出现咔嗒声或其他受阻或故障的迹象, 否则不要操作起重机。
- 马达**: 如果性能不良, 拆卸马达并检查轴承和轴是否有磨损或损坏。应当对部件进行清洁、润滑和重新装配。更换磨损或损坏的部件。
- 制动器**: 升起等同于起重机额定容量的载荷 4 到 6 英寸 (100 到 150 mm) 来检查起重机操作。检查起重机在保持载荷时是否没有漂移。如果发生漂移, 则进行拆卸。如“维护”部分中所述, 拆下制动盘。在每次拆卸起重机时, 检查并清洁制动部件。如果厚度小于 0.090 英寸 (2.29 mm), 则更换制动盘。
- 支撑结构**: 检查是否扭曲、磨损, 以及能否持续支撑载荷。
- 吊车 (如果配备)**: 检查吊轮是否正确沿着梁行进, 并且每个轮缘和梁之间的距离正确, 介于 3/32 至 1/8 in. (2 至 3 mm)。检查轮和梁是否过度磨损。检查侧板是否由于弯曲而拉伸。在确定并修正所有问题之后, 方可操作起重机。

表 2

起重机型号	喉部宽度 (在安装了栓锁的情况下)											
	标准				青铜				Bullard Burnham			
	新吊钩		废弃吊钩		新吊钩		废弃吊钩		新吊钩		废弃吊钩	
	in	mm	in	mm	in	mm	in	mm	in	mm	in	mm
HL1000K	1.06	26.9	1.17	29.7	1.36	34.5	1.5	38	1.25	31.8	1.38	35
HL1500K	1.06	26.9	1.17	29.7	1.36	34.5	1.5	38	1.25	31.8	1.38	35
HL2000K	1.38	35	1.52	38.5	1.61	40.9	1.77	44.98	1.50	38.1	1.65	41.9
HL3000K	1.69	43	1.86	47.3					1.88	47.8	2.07	52.6
HL4500K					2.08	52.8	2.29	58.19	3.00	76.2	3.3	83.4
HL6000K	2.09	53.1	2.3	58.4	3.02	76.7	3.32	84.38	3.00	76.2	3.3	83.4

9. **标签和标记:** 检查是否存在并且清晰可辨。如有必要, 请予以更换。
10. **载荷链和锚:** 确保载荷链的两个端部都牢固附接。如果松动则进行固定, 如果损坏则进行维修, 如果缺失则进行更换。
11. **载荷链:** 如图MHP1291 中所示测量载荷链五个链节段上的磨损情况。请特别注意绕上钢丝绳频率最高的链节。如果工作长度上的任意五个链节达到或超出表 3 中的废弃长度, 则更换整根链。务必使用原装的 Ingersoll Rand 材料搬运更换链。

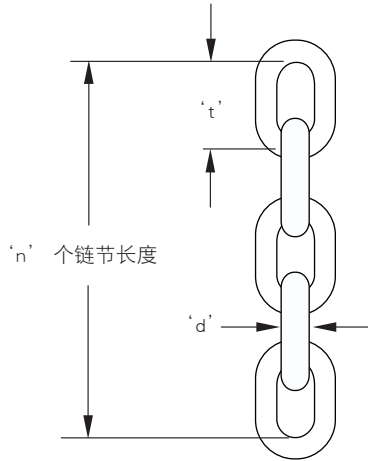

(图MHP1219)

表 3 载荷链长度

链节尺寸		链节数目 (n)	废弃长度 (n) 个链节
标称钢丝直径 (d)	节距 (t)		
3/8	1.012 in	5	5.161 in
	25.7 mm		131.1 mm

自 1996 年 1 月起, 镀锌的载荷链是 HLK 起重机上的标配。在 HL1000KR 防火花起重机上, 务必使用不锈钢载荷链

12. **链条箱:** 检查链条箱是否损坏或有过度磨损, 并且链条箱牢固附接至起重机。根据需要进行固定或更换。
13. **限制装配:** 检查节流阀杆是否顺畅移动。要限制吊钩向下的行程, 则松弛链侧中的回路必须接触节流阀杆。为了限制吊钩向上行程, 底部吊钩块或止挡环必须接触节流阀杆。

要测试“向上”和“向下”行程限制, 先在没有载荷的情况下缓慢运行起重机, 检查是否正常工作。在没有载荷的情况下全速重复测试, 以验证是否正常工作。在起重机型号 HL4500K 和 HL6000K 上, 节流阀杆 (35) 可能需要细微调节, 以和上悬挂块之间保持足够间隙。

■ 非常规使用的起重机

1. 对于闲置时间为一个月或更长时间但不超过一年的起重机, 在投入使用前, 应该根据“经常性检查”的要求进行检查。
2. 对于闲置时间超过一年的起重机, 在投入使用前, 应该根据“定期检查”的要求进行检查。
3. 根据“经常性检查”要求, 备用起重机应该至少每半年检查一次。在非正常工作条件下, 应当以更短的间隔检查起重机。

检查和维修报告

Ingersoll Rand HLK 空气链起重机

型号:	日期:
序列号:	检查者:
检查原因: (选中适用的框)	
1. 计划定期检查: ___ 每季度 ___ 每半年 ___ 每年 2. 经常性检查期间发现的问题 3. 维护期间发现的问题 4. 其他: _____	工作环境: ___ 一般 ___ 重度 ___ 严重

有关一般检查标准, 请参考部件、操作和维护手册的“检查”部分。请参考适用的国家实践标准和准则。如果对当前状况有任何疑问, 请联系最近的 Ingersoll-Rand 经销商或工厂以获得技术支持。

组件	状况		纠正措施		注意
	通过	失败	修理	更换	
紧固件					
齿轮					
轴					
轴承			---		
载荷轴承绞缆轮					
链条导板					
弹簧			---		
罩					
吊钩:					
顶部	实际吊钩喉部宽度: _____ 英寸 / _____ mm (有关可接受的最小/最大宽度, 请参考表 2。)				
	吊钩扭曲			---	(最大 10%)
	所用的吊钩裂纹测试方法: ___ 染料渗透剂 ___ 磁性微粒 ___ 其他: _____				
底部	实际吊钩喉部宽度: _____ 英寸 / _____ mm (有关可接受的最小/最大宽度, 请参考表 2。)				
	吊钩扭曲			---	(最大 10%)
	所用的吊钩裂纹测试方法: ___ 染料渗透剂 ___ 磁性微粒 ___ 其他: _____				
吊钩栓锁 (标配)			---		
吊钩关口 (Bullard)			---		
制动器 (10% 载荷测试)			---		
制动器 (目视检查)					
尾销 (末端锚)					
载荷链:			---		
工作长度最大磨损: _____ 英寸 / _____ mm (请参考表 3)					
支撑结构					
标签和标记			---		
其他组件 (列在“注意”部分)					

测试:	通过	失败	注意
操作 (无载荷)			
操作 (10% 载荷)			
操作 (最大测试载荷 *)			

* 请参考“维护”部分中的部件、操作和维护手册“载荷测试”以确定最大测试载荷。
 该页面可由检查者或维护人员进行影印和使用。

润滑

要确保起重机持续有效操作，必须按照每个组件指示的合适时间间隔，使用正确的润滑油对所有需要润滑的点进行维护。正确润滑是保持高效操作最重要的因素之一。

本手册推荐的润滑间隔是基于起重机间歇运行，每天工作 8 小时，每周工作 5 天。如果起重机几乎是连续运行，或每天的运行时间超过 8 小时，则需要更频繁地进行润滑。润滑油类型和更换间隔是基于相对无灰尘、无湿气且无腐蚀性烟雾的工作环境。只能使用推荐的滑润剂。其他润滑油可能会影响起重机性能。要使用其他润滑油，必须获得 IngersollRand 技术支持部门或经销商的批准。不正确地进行润滑可能会导致起重机及其相关组件损坏。

时间间隔	润滑检查
每个班次开始时（操作员）	当在最大马达速度下操作起重机时，检查供气管润滑器的流速和油位（大致每分钟需要滴出 1 到 3 滴润滑油）。
每周（维护人员）	清洁并润滑载荷链。
	润滑吊钩栓锁和枢轴点。
每月（维护人员）	检查并清洁或更换供气管过滤器。
每年（维护人员）	排空并更改壳体油。

注意：时间间隔基于“检查”部分所述的起重机正常工作环境。在“重度”或“严重”工作条件下，应当相应地调整润滑间隔。

■ 一般润滑

分解 Series HLK 起重机进行大修或更换时，请进行如下润滑工作：

1. 将所有马达部件轻涂一层 Ingersoll Rand Pneu-Lube 50 号中等油或高质量液压油，然后再开始装配。



小心

- 请勿使用汽车用洗涤剂。洗涤剂将会让马达叶片脱层，导致永久性故障。
2. 向节流阀轴轴承 (2) 施加 Ingersoll Rand 70 号油脂或多用途油脂然后再开始装配。
 3. 用 Ingersoll Rand 62 号油或 Texaco Meropa 220 号加注齿轮箱至壳体 (1) 侧油位塞。更换油位塞并在加注之后将塞排空。
 4. 顶部和底部吊钩由推力轴承支撑。
这些轴承必须定期使用 IngersollRand 68 号滑脂或标准的 2 号多功能滑脂涂抹。如果不加以适当的润滑，将导致轴承出现故障。

■ 串联润滑器

通过串联润滑器，用 Ingersoll Rand Pneu-Lube 10 号（或 SAE 10）中等油或 50 号（SAE 20 或 20W）未净化的机油润滑马达。使用净化油可能导致永久性故障。

■ 载重链



警告

- 如果不能保持载荷链清洁和良好润滑，将会导致严重的载重链磨损，从而导致链故障，进而导致严重的伤害、死亡或重大财产损失。

1. 每周对载重链的每个链节加以润滑。在已有涂层上涂敷新的滑润剂。
2. 在恶劣应用环境或腐蚀环境中，需要比正常更高的频率加以润滑。
3. 使用与载荷链条相同的润滑油润滑挂钩和挂钩锁栓枢轴部位。
4. 如果需要，请使用无酸溶剂清洁链条，去除锈迹或研磨性积垢，然后对链条加以润滑。
5. 使用 Ingersoll Rand LUBRI-链节-GREEN 或 SAE 50 至 90 EP 油。

■ 吊钩和选件组件

1. 对吊钩和锁栓销点加以润滑。吊钩和插销应能自由回转或绕轴转动。
2. 使用 Ingersoll Rand LUBRI-链节-GREEN 或 SAE 50 至 90 EP 油。
3. 在 HL4500K 和 HL6000K 起重机上，用 Ingersoll Rand 68 号油脂或优良品质的 2 号多功能油脂润滑上方悬架壳体 (101) 和下方吊钩块 (123) 中的惰轮轴承 (107)。
4. 在 HL4500K 和 HL6000K 起重机上，如果是在污染环境下工作，在每工作 300 小时以后或以更短间隔从油脂枪喷射 2 或 3 次油脂到惰轮轴 (110) 末端的注油脂附件 (111) 中。

■ 壳体

从壳体 (1) 侧拆下油位塞。如果油位低于螺纹孔，则拆下透气塞，并添加足量的 Ingersoll-Rand 62 号油（Texaco Meropa 3 号或 Texaco Meropa 220 号）。重新安装油位塞和通风塞。

■ 其他系统部件

请参阅系统部件随附的制造商手册的“润滑”部分，了解润滑要求。

维护

警告

- 当起重机在支撑载荷时，切勿在起重机上执行维护。
- 在执行维护之前，标记控件：
危险 - 请勿操作正在修理的设备。
- 只能让在本起重机保养和维修方面接受过指导的人员执行维护。
- 在起重机上执行任何维护之后，根据 ASME B30.16 标准动态测试起重机直至达到其额定容量的 100%，然后再重新将起重机投入使用。要在额定容量 100% 以上进行测试，可能需要遵守美国以外地区制定的标准和规定。
- 关闭空气系统并将空气管路泄压，然后再执行任何维护。

维护间隔

维护间隔图表基于起重机一周五天、每天八小时的间歇操作，工作环境相对无尘、无湿气、无腐蚀性烟气。如果起重机几乎是连续运行，或每天的运行时间超过 8 小时，则应当更频繁地进行维护。

时间间隔	维护检查
每个班次开始时（操作员或维护人员）	彻底地目视检查起重机是否有损坏。如果起重机损坏，请勿操作。 以两个方向操作起重机。起重机必须顺畅工作没有卡滞、受阻或异常噪声。检查制动器的工作情况。
每隔半年（维护人员）	检查制动器。根据需要清洁或更换部件。按需调节制动器。
每年（维护人员）	检查起重机传动装置、轴和轴承是否有磨损和损坏。按需要进行修理或更换。 检查所有支撑构件，包括悬架、紧固件、螺母、绞缆轮和索具等是否有损坏或磨损迹象。按需要进行修理或更换。

一般维护说明

必须记录在起重机上执行的所有维护工作，并在检查报告上注明日期。

正确的使用、检查和维护将增加 Ingersoll Rand 设备的使用寿命和有效性。装配过程中，用适用润滑油润滑齿轮、螺母、有头螺钉和所有加工螺纹。在有头螺钉和螺母螺纹区域使用防粘剂和/或螺纹润滑油，防止腐蚀并让部件便于拆卸。

建议在洁净、无尘的工作区域的工作台上执行起重机上的工作。在拆卸起重机过程中，遵照以下方面：

- 关闭空气系统并将空气管路泄压，然后再执行任何维护。将空气管路与起重机断开连接。
- 在拆卸起重机时，切勿超出维修所需范围。在拆卸过程中可能会损坏良好的部件。
- 在拆卸部件时切勿过度用力。例如，可用软锤围绕护盖或壳体周边轻轻敲击，这样已足以损坏密封件。
- 请勿用火焰加热部件以使其松动来进行拆卸，除非要加热的部件已经磨损或损坏，并且已不用再修理，同时不会对其他部件造成损坏。

一般而言，起重机采用便于拆卸和装配的设计。不应当使用热量或过大的力。

- 让工作区域保持洁净，防止灰尘或其他异物进入轴承和其他移动部件。
- 一旦拆下密封件、垫圈和 O 型环，则应当废弃所有拆下的此类部件。在装配起重机时应当使用新的密封件和 O 型环。

- 当把零件夹在虎钳上时，务必使用皮包或铜包虎钳夹以保护零件表面，防止变形。这是真正的丝扣零件、加工表面和壳体。
- 除非更换和修理需要，不得拆卸压配零件或局部装配组件。
- 为了在起重机装配或拆卸期间避免损坏，对于轴配合轴承务必敲击或按压轴承内座圈，对于孔配合轴则是外座圈。
- 如果必须在身体高度以上执行维修工作，则应当有合适的工作平台或梯子供使用。

载荷链护理

如“润滑”部分中所说明，让链保持良好润滑。当载荷链不能顺畅无碍地进入和退出链轮时，或者当发出受限或其他故障引起的噪声时，切勿操作起重机。

如果链条有目视可见的损坏，请更换链条，并检查链轮和链罩。如果旧链轮有可见磨损，则安装新的链轮。如果旧链轮损坏或扭曲，则安装新链罩。

有关载荷链检查的信息，请参考“检查”部分。

小心

- 目视检查无法确定所有的载荷链条损坏。只要出现任何链条磨损迹象，则检查链条和链轮。请参考“检查”部分。

起重机随附的标准链条已表面硬化至 0.010 至 0.012 英寸（0.25 至 0.35 mm）的深度。当外部硬化表层损坏时，将会加快磨损速度，并且链条的强度将会大幅降低。

另外，链条将不再正确适配起重机链轮中的凹陷部，致使链轮迅速磨损。这样会大幅增加起重机故障和链条断裂的几率。

在根据建议更换链条的情况下，起重机链轮设计成能够持续使用几个链条更换周期。

初始链安装

以下说明适用于没有安装载荷链的起重机。对于安装了载荷链并且必须更换载荷链的起重机，请参考“链条更换”部分。当涉及拆卸或安装起重机部分或子组件以辅助链条安装时，请参考适用的“拆卸”或“装配”部分以了解具体要求。

HL1000K、HL1000KR 和 HL1500K

以下步骤说明了在没有安装载荷链的单倒链起重机上进行的初始安装操作。

- 拆下制动器弹簧和活塞壳体、制动盘和制动板，以露出制动驱动器。
- 从和链条锚螺栓相对的链轮侧，将载荷链的第一链节的边缘接合在链轮凹陷部中。请参阅图 TPA706-4，“链条安装 - 步骤 1”。载荷链链节上的焊缝必须背离动力驱动的链轮。请参阅图 MHP0472。
- 用手旋转制动器驱动器以进给载荷链穿过起重机。

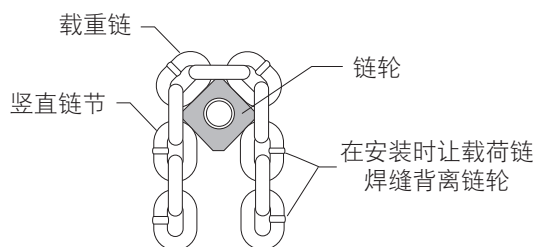

(图MHP0472)

链条安装 - 步骤 1

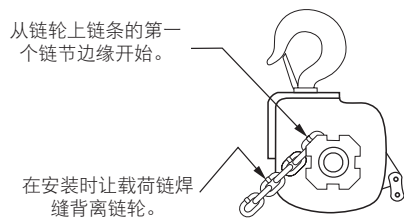

(图TPA706-4)

4. 让载荷链保持笔直并且不要扭曲它。将载荷链的自由端附接至连接链节。请参阅图TPA706-3, “链条安装 - 步骤 2”。清洁、检查并安装起重机上的制动器弹簧、制动盘、制动板和活塞壳体。

链条安装 - 步骤 2

5. 将载荷链的自由端附接至吊钩。在缓慢操作起重机的同时检查链条。确保链条顺畅进给通过链轮, 没有卡滞和阻碍。以相反方向重复操作。

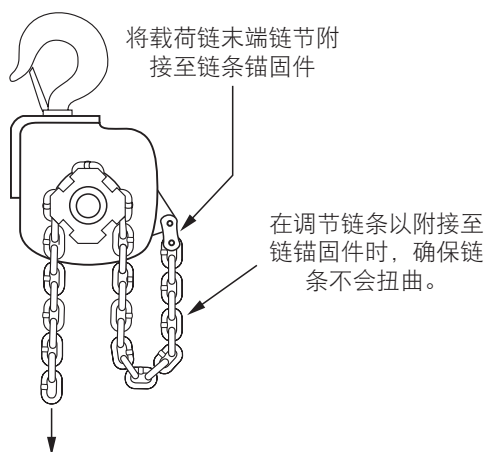

连接至 HL1000K、HL1000KR 和 HL1500K 起重机上的吊钩; 连接至 HL2000K 和 HL3000K 起重机上的底部块组件

(图TPA706-3)

■ HL2000K 和 HL3000K

以下步骤说明了在没有安装载荷链的双倒链起重机上进行的初始安装操作。

1. 完成“HL1000K、HL1000KR 和 HL1500K 链条安装”部分的步骤 1 至 4。参考 MHP0472、TPA706-4 和 TPA706-3。

警告

- 更换 HLK 双倒链起重机的链条时, 链节的总数必须为奇数。请参阅图MHP0441。

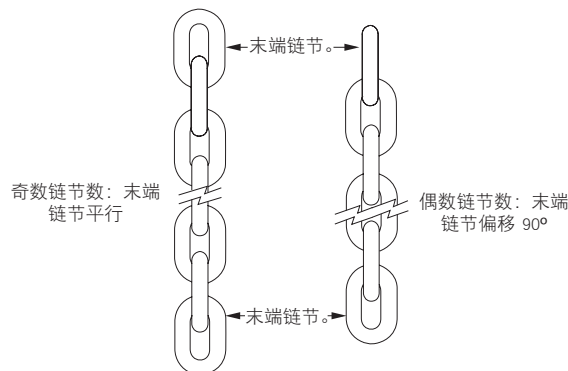

(图MHP0441)

2. 确保链条笔直并且进给末端穿过底部吊钩链轮, 其中第一链节边缘上的焊缝朝向惰链轮的内部。请参阅图TPA706-2, “链条安装 - 步骤 3”。

链条安装 - 步骤 3

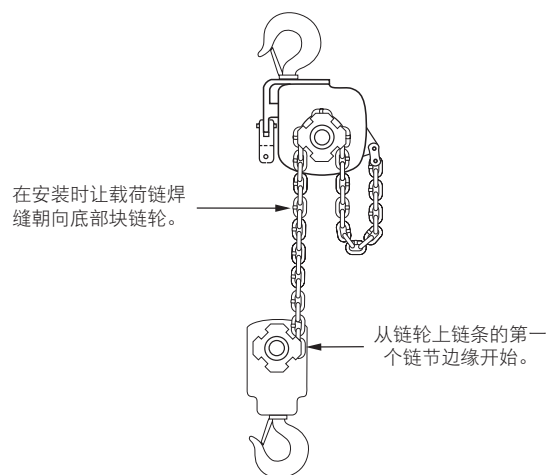

(图TPA706-2)

3. 确保链条笔直, 并将自由端附接至链条锚支架。请参阅图 TPA706-1, “链条安装 - 步骤 4”。

链条安装 - 步骤 4

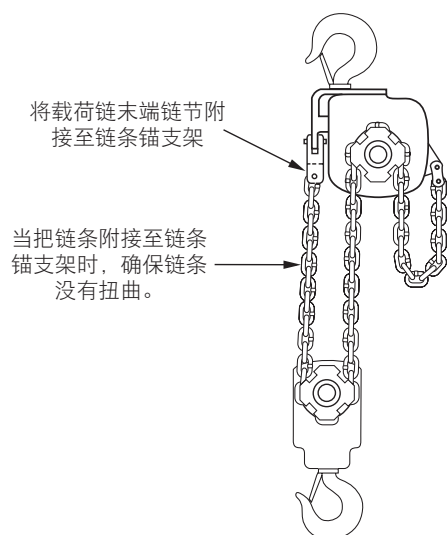

(图TPA706-1)

4. 进行检查，确保链条没有扭曲、扭结或“翻转”。请参阅图MHP0020 和 MHP0043。

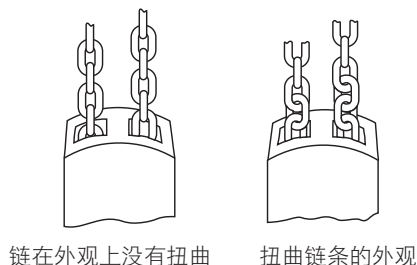

(图MHP0020)

翻转的吊钩

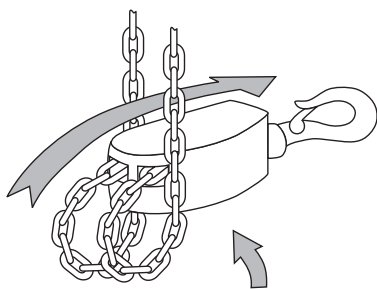

(图MHP0043)

HL4500K 和 HL6000K

以下步骤说明了在没有安装载荷链的三或四倒链起重机上进行的初始安装操作。

1. 拆下制动器弹簧和活塞壳体、制动盘和制动板，以露出制动驱动器。
2. 将载荷链的第一链节的边缘置于起重机动力驱动的链轮的凹陷部中。请参阅图MHP0472。载荷链链节上的焊缝必须背离动力驱动的链轮凹陷部。

小心

- 不当地安装载荷链将致使链轮永久磨损，导致设备损坏，继而可能造成人身伤害或财产损坏。
3. 以固定端链条锚固件的方向（升起方向），用手旋转制动器驱动器以进给载荷链穿过起重机。
 4. 让载荷链保持笔直并且不要扭曲它。将载荷链的自由端附接至连接链节。请参阅图TPA1056（针对 HL4500），以及图TPA1057（针对 HL6000K）。清洁并检查制动器部件并装配。
 5. 在 HL6000K 起重机上，将限位止挡管滑动到载荷链上。
 6. 让载荷链保持笔直，如 HL4500K 或 HL6000K “起重机载荷链穿接”部分所述完成载荷链安装。

HL4500K 起重机载荷链穿接

请参阅图TPA1056。

当载荷链正确安装到起重机动力驱动的链轮上之后，必须如本部分中所述小心穿过下方块惰链轮、上方悬架惰链轮并固定至底部块壳体。

警告

- 扭曲的载荷链可能在经过链轮时卡住，对起重机造成损害，或者让载荷链断裂，从而造成人身伤害或财产损失。

1. 将底部吊钩块升起至起重机附近位置，在其中其可正确地受到支撑并且被阻止移动。
2. 确保载荷链保持笔直。将载荷链穿过底部块惰链轮。

注意

- 属于动力驱动的链轮上的竖直链节的载荷链链节也是底部块惰链轮上的竖直链节。

3. 确保载荷链保持笔直。将链条穿过惰链轮的上方悬架。

注意

- 属于动力驱动的链轮和底部块链轮上的竖直链节的载荷链链节为上悬架惰链轮上的平坦链节。

■ HK4500K 起重机链穿接

安装载荷链，让焊缝背向动力驱动的链轮和上悬架惰链轮

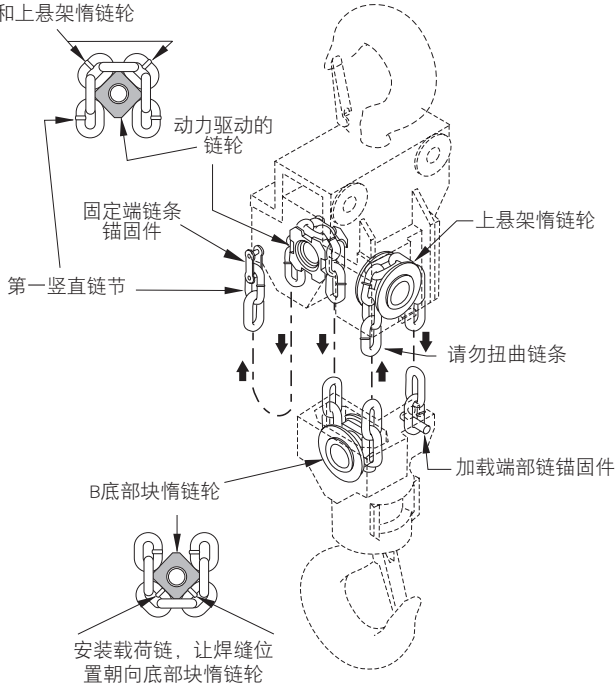

(图TPA1056)

4. 确保载荷链保持笔直。进给载荷链穿过上悬架惰链轮并将末端链节插入底部块载荷末端链锚固件。在将载荷链附接至载荷末端链锚固件时，请勿弯曲它。如果需要，从载荷链上切割最后一个链节（参考图MHP0441）并将其拆下，以防止扭曲。使用锚销将其固定到位。

注意

- 底部块组件可能需要进行调节，以确保沿着每个载荷轴承下降的长度，其与相当数量的载荷链链节齐平。要将底部块组件调平，可根据需要进给载荷链穿过底部块和上悬架惰链轮，以“平衡”底部块组件。确保动力驱动的链轮不会在调节期间转动。
- 5. 如“润滑”部分中所述的润滑载荷链。以两个方向完全操作起重机而不附接载荷。起重机必须顺畅运转而没有卡滞、约束或链条“跳动”现象。如“测试”部分中所述全面测试起重机，然后再重新投入使用。

■ HL6000K 起重机电荷链穿接

请参阅图TPA1057。

当载荷链正确安装到起重机电力驱动的链轮上之后，必须如本部分中所述小心穿过下方块惰链轮、上方悬架惰链轮并固定至壳体。

警告

- 扭曲的载荷链可能在经过链轮时卡住，对起重机造成损害，或者让载荷链断裂，从而造成人身伤害或财产损失。
1. 将底部吊钩块升起至起重机附近位置，在其中其可正确地受到支撑并且被阻止移动。

■ HL6000K 起重机电荷链穿接

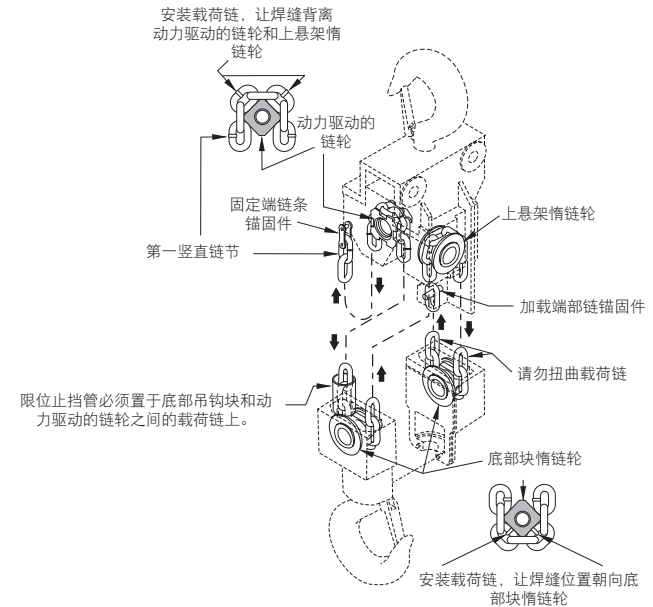

(图TPA1057)

2. 确保载荷链保持笔直。将限位止挡管置于载荷链上并进给载荷链穿过底部块惰链轮。

注意

- 属于动力驱动的链轮上的竖直链节的载荷链链节也必须是底部块惰链轮上的竖直链节。
3. 确保载荷链保持笔直。将链条穿过惰链轮的上方悬架。

注意

- 属于动力驱动的链轮和底部块链轮上的竖直链节的载荷链链节必须为上悬架惰链轮上的平坦链节。
4. 确保载荷链保持笔直。进给载荷链穿过第二底部块惰链轮。将末端链节插入上悬架载荷末端链锚固件。在将载荷链附接至载荷末端链锚固件时，请勿弯曲它。如果需要，从载荷链上切割最后一个链节（参考图MHP0441）并将其拆下，以防止扭曲。使用锚销将其固定到位。

注意

- 底部块组件可能需要进行调节，以确保沿着每个载荷轴承下降的长度，其与相当数量的载荷链链节齐平。要将底部块组件调平，可根据需要进给载荷链穿过底部块和上悬架惰链轮，以“平衡”底部块组件。确保动力驱动的链轮不会在调节期间转动。
5. 如“润滑”部分中所述的润滑载荷链。以两个方向完全操作起重机而不附接载荷。起重机必须顺畅运转而没有卡滞、约束或链条“跳动”现象。如“测试”部分中所述全面测试起重机，然后再重新投入使用。

■ 链条更换

以下说明描述了安装了链条的起重机上的载荷链的更换。如果载荷链已拆下，则必须按“初始链条安装”部分中所述，将其重新安装或更换。当涉及拆卸或安装起重机部分或子组件以辅助链条安装时，请参考适用的“拆卸”或“装配”部分以了解具体要求。

⚠️ 小心

- 损坏的载荷链可能导致链轮磨损或损坏，并且导致起重机故障、人身伤害或财产损失。必须拆下磨损或损坏的载荷链，并检查起重机和拆下的底部块组件以及动力驱动的链轮和惰链轮，然后再继续操作起重机。
- 请勿在起重机支撑载荷的情况下尝试更换载荷链。卸下所有载荷。
- 以下程序使用动力驱动的起重机操作。务必特别小心，在操作起重机时，确保工作条件安全无虞，以防止人身伤害和起重机或财产损失。

通过使用现有的载荷链来安装新载荷链，可有效而便利地完成所有起重机型号的载荷链更换。

1. 将起重机吊钩（HL1000K、HL1000KR、HL1500K）或吊钩块（HL2000K、HL3000K、HL4500K、HL6000K）升起至起重机附近位置，在其中其可正确地受到支撑并且被阻止移动。
2. 将载荷链载荷末端链节从吊钩（HL1000K、HL1000KR、HL1500K）或载荷末端链锚固件（HL2000K、HL3000K、HL4500K、HL6000K）上拆下。在HL2000K和HL3000K上，从底部块拆下载荷链。
3. 使用砂轮，从末端链节上切割一部分，以形成“C”型链节，如图MHP0502中所示。

⚠️ 小心

- 请勿以任何方式扭曲链节。它必须能够穿过链轮而没有阻碍。

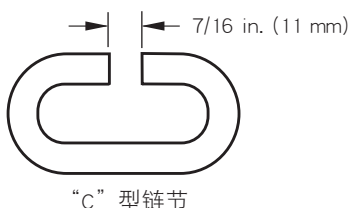

“C”型链节

(图MHP0502)

4. 将新链条连接至旧链条，方法是将新链条的末端插入“C”型链节。确保新链条上的焊缝和链节匹配正在更换的链条上的焊缝和链节的定位。
5. 以下特定于起重机的说明描述了完成您起重机上的载荷链更换必须采取的步骤。

■ HL1000K、HL1000KR 和 HL1500K 链条更换

完成“链条更换”中所述的初始步骤。在单倒链起重机上执行以下额外步骤以完成载荷链更换安装。

1. 以升起方向缓慢操作起重机以剥离旧链条并将新的链条穿接在链轮上方。
请参阅图TPA706-4。

注意

- 动力驱动的链轮上方新链条的第一链节必须为竖直链节。
2. 在新链条穿接在动力驱动的链轮上方之后，拆下旧链条和“C”型链节。将载荷链的固定端固定至起重机上的固定端链锚固件。请参阅图TPA706-3。确保载荷链不会在链轮和固定端链锚固件之间扭曲。
 3. 润滑载荷链。请参考“润滑”部分。

4. 旋转载荷链中的最后一个链节，使其垂直于下个链节，其中焊缝朝下，朝向吊钩。请参考部件图MHP1105。将吊钩附接至载荷链的载荷末端。以两个方向缓慢操作起重机。起重机必须顺畅运转，没有卡滞或约束。

■ HL2000K 和 HL3000K 链条更换。

完成“链条更换”中所述的初始步骤。在双倒链起重机上执行以下额外步骤以完成载荷链更换安装。

1. 以升起方向缓慢操作起重机以剥离旧链条并将新的链条穿接在链轮上方。
请参阅图TPA706-4。

注意

- 在双倒链起重机上，载荷链链节的总数必须为奇数。确保新载荷链具有奇数的链节总数。
请参阅图MHP0441。
 - 动力驱动的链轮上方新链条的第一链节必须为竖直链节。
2. 在新链条穿接在动力驱动的链轮上方之后，拆下旧链条和“C”型链节。将载荷链的固定端固定至起重机上的固定端链锚固件。
请参阅图TPA706-3。确保载荷链不会在链轮和固定端链锚固件之间扭曲。
 3. 围绕底部块惰链轮穿接载荷链的载荷端部。确保链不会在起重机链轮和底部块链轮之间扭曲。
请参阅图TPA706-2。
 4. 确保载荷链保持笔直并将载荷链的载荷端部附接至起重机上的链锚固件支架。
请参阅图TPA706-1。
 5. 润滑载荷链。请参考“润滑”部分。
 6. 以两个方向缓慢操作起重机。起重机必须顺畅运转，没有卡滞或约束。

■ HL4500K 和 HL6000K 链更换

完成“链条更换”中所述的初始步骤。在三和四倒链起重机上执行以下额外步骤以完成载荷链更换安装。请参阅图TPA1056（针对HL4500K起重机）和TPA1057（针对HL6000K起重机）。

1. 让新载荷链保持笔直，以升起方向缓慢操作起重机，从而剥离旧载荷链，并将新载荷链穿接在动力驱动的和惰链轮上方。

注意

- 确保新链条上的焊缝和链节匹配正在更换的链条上的焊缝和链节的定位。必须安装新链条，使其穿接起重机，位于动力驱动的链轮上方的新载荷链的第一个链节将为竖直链节，其焊缝背向动力驱动的链轮。
2. 在新载荷链穿接在动力驱动的链轮上方之后，将旧链条从起重机侧的固定端链锚固件上拆下，并附接新链条的端部。确保载荷链不会在动力驱动的链轮和固定端链锚固件之间扭曲。

⚠️ 警告

- 扭曲的载荷链可能会在经过链轮上方时卡住，损坏起重机，并且可能让链条断裂，造成人身伤害或财产损失。
3. 让载荷链的载荷端部保持笔直，将载荷端部链节附接至位于底部块（HL4500K）或上悬架壳体（HL6000K）中的载荷末端链锚固件。在将链条附接至载荷末端链锚固件时，请勿弯曲它。如果需要，从载荷链切割最后一个链节，并将其拆下，以防止扭曲。
请参阅图MHP0441。
 4. 润滑载荷链。请参阅“润滑”部分。

5. 在动力驱动下无负载向上和向下运行吊钩数次，确保链条在链轮上方顺畅运行。不得有明显的阻碍或故障迹象。

■ 维修过滤器和滤网

1. 将气源与起重机断开连接。
2. 将空气软管从入口滤网 (24C) 上旋松。
3. 将入口滤网从入口主体 (23) 上旋松。
4. 清洁入口滤网内部的网，方法是以优质、无毒、非易燃溶剂在通风良好的区域进行冲洗。如果网损坏或无法清洁，请更换入口滤网。
5. 从阀门室 (6) 旋松入口螺栓 (24) 并从阀门室拆下入口螺栓和入口主体。
6. 将入口螺栓从入口主体推出。
7. 从入口螺栓拆下两个旋转入口密封件 (24A)。
8. 如果旋转入口垫圈 (24B) 损坏，则将其更换。
9. 如果起重机设备在入口螺栓内有过滤器，则通过以优质、无毒、非易燃溶剂在通风良好的区域进行冲洗来进行清洁。如果无法清洁过滤器，则更换入口螺栓。（新型入口螺栓没有过滤器）。
10. 用 O 型环润滑油润湿新旋转入口密封件，并将它们安装在围绕入口螺栓的主体的凹槽中。
11. 将入口螺栓推到入口主体中，直至螺栓的“六角”头与入口主体的表面齐平。
12. 让入口主体的螺纹孔保持背离起重机，并将入口螺栓旋入阀门室。
13. 将入口滤网旋入到入口主体中。
14. 将空气软管旋入到入口滤网中。
15. 将气源重新连接至起重机。

拆卸

警告

- 断开气源软管连接，然后再于本起重机上执行任何维护或维修工作。

请参考“一般维护说明”并另外注意：

- HLK 起重机由各种模块构成。在拆卸过程期间，并非总是需要拆卸特定模块，因为它可能已经从起重机上卸下。例如，必须拆下阀门室组件（以组件形式）以触及并拆卸马达。然而，不需要拆卸阀门室，除非阀门室内的部件需要更换。在更换或维修已损件时，请勿过度拆卸起重机。
- 在拆卸本起重机时，必须具备全套新垫圈、O 型环和密封件以用于更换。这些都可在大修垫圈套件编号 HLK-K445 中获得。惰轮密封件 (108) 和吊钩销 (130) 未包含在套件中并且必须单独订购。
- 请勿尝试清洗密封轴承。

新型阀门室拆卸

本程序描述了起重机上使用的阀门室的拆卸，这些起重机序列号的第二个字母并非 A 至 G 中的一个，或者序列号的第二个和第三个字母并非 HA、HB 或 HC。更换部件编号列在部件部分。请参阅图 TPA958-1。

- 在带有控制板控件的起重机上，将三根控制板软管 (171) 与接头 (181) 和 (182) 断开连接。拆下阀门室板螺钉 (30) 并且断开抗拉电缆 (175)。
- 拆下控制板链节 (183)。
- 旋松阀门室螺钉 (26) 和 (27) 并拆下阀门室 (6) 和阀门室垫圈 (25)。
- 旋松并拆下旋转入口组件。将入口螺栓 (24) 从入口主体 (23) 推出以露出旋转入口密封件 (24A)。
- 旋松阀门室有头螺钉 (22) 并拆下阀门室盖 (18) 和阀门室盖垫圈 (16)。
- 拆下活塞和活塞轴组件 (14 和 15) 以及活塞弹簧 (13)。
- 拆下阀座锁紧螺钉 (11)。
- 当对阀座 (10) 施加压力时，使用扣环钳拆下阀座固定器 (12)。
- 使用带钩工具，从阀门室拉动阀座或在木质块上敲击阀门室的底部。
- 从阀门室拆下阀组件 (7) 和 (8) 和阀弹簧 (9)。
- 如果活塞轴密封件 (15A) 需要更换，从每个轴承和轴按下活塞定位销 (15B) 并将活塞从轴上滑下。

旧式阀门室拆卸。

本程序描述了起重机上使用的阀门室的拆卸，这些起重机序列号的第二个字母为 A 至 G 中的一个，或者序列号的第二个和第三个字母为 HA、HB 或 HC 中的一个。请参阅图 TPA883-3。

注意

- 该阀门室的更换部件不再提供。如果已无法维修，订购套件编号 MLK-K545B (03835519) 来更换该型号阀门室。

- 在带有控制板控件的起重机上，将弯管 (181) 和 (182) 处的三根控制板软管 (171) 断开连接。拆下阀门室板螺钉 (30) 并且断开抗拉电缆 (175)。
- 旋松并拆下入口滤网 (24C)。
- 旋松阀门室螺钉 (26) 和 (27) 并拆下已装配的阀门室和阀门室垫圈 (25)。
- 旋松并拆下旋转入口组件。将入口螺栓 (24) 从入口主体 (23) 滑出以露出旋转入口密封件 (24A)。
- 旋松阀门室盖有头螺钉 (339)，并连同活塞杆 (328) 和 (329)、活塞 (330) 和活塞弹簧 (333) 一起收回阀门室盖 (334)。拆下阀门室盖垫圈 (338)。

- 收回两个阀门 (325) 和两个阀门弹簧 (327)。

注意

- 阀门 (325) 和套筒是以匹配的套件形式制造。请勿将阀门和套筒弄混。在拆卸时确保阀门针对套筒位置进行了标记。

制动器拆卸

请参阅图 TPB704-3。

- 旋松四颗肩部螺钉 (89) 和锁紧垫圈 (90) 并将弹簧 (81) 和活塞壳体 (80) 作为组件与齿轮箱盖 (69) 分离。

注意

- 在装配期间，当组件分离为组成部件时，应当废弃露出的 O 型环和垫圈，并用新的进行更换。
- 从齿轮箱盖拆下制动板 (78) 和制动盘 (79)。拆下 O 型环 (空气口) (77) 并废弃。
 - 如下拆卸弹簧和活塞壳体：
 - 拆下板螺钉 (88) 和板 (87)。
 - 将组件、压力板 (82) 向下放置在手扳压机上，或者将组件垂直放置在虎钳中。
 - 当对着弹簧 (81) 压紧方向保持住壳体时，用扳手保持住压力板螺钉 (82A) 并旋松活塞螺母 (82B)。
 - 通过小心地在手扳压机或虎钳上放松，消除压缩弹簧 (81) 的张紧状态。
 - 拆下压力板并从壳体推动活塞 (83)。拆下 O 型环 (84) 和 (85) 并废弃。
 - 要拆下制动器驱动器 (73)，拆下护圈螺钉 (76) 和制动器密封件固定器 (74)。将制动器驱动器从马达轴 (38) 上滑下。拆下制动器密封件 (75) 并废弃。

马达拆卸

请参阅图 TPA958-1 和 TPB703-3。

- 拆下制动器机构。请参阅“制动器拆卸”部分。
- 从齿轮箱排放油。
- 以组件形式拆下阀门室 (6)。请参考适用的（新式或旧式）阀门室拆卸部分。
- 拆下限制执行器定位销 (34) 并收回限制执行器 (33)。
- 旋松剩余的阀门室板螺钉 (30) 并拆下阀门室板 (28)。
- 抓住后端板 (41) 并以组件形式从起重机拉动马达。如果马达显得有一点“卡滞”，则用软锤敲击马达轴 (38) 的制动器端进行松动。
- 垂直地将马达轴固定在铜包虎钳夹中。
- 拆下马达轴后固定环 (39)。
- 将后端板 (41)、后端板轴承 (40)、气缸 (44)、气缸定位销 (45)、叶片 (43)、转子 (42)、前端板 (46) 和前端板轴承 (47) 分离成组成部件。

拆卸传动装置、凹陷部轮、链条导板、链罩和节流阀轴

请参阅图 TPB705-2 和 MHP1065。

注意

- 在装配期间，当组件分离为组成部件时，应当废弃露出的 O 型环和垫圈，并用新的进行更换。
- 拆下制动器机构。请参阅“制动器拆卸”部分。
 - 拆下马达。请参阅“马达拆卸”部分。
 - 拆下四颗齿轮箱有头螺钉 (70) 和锁紧垫圈 (71)。拆下齿轮箱盖 (69)。可能必须使用外接至杆并固定至两颗制动器盖螺栓孔的滑动锤拉器。

4. 拆下齿轮箱盖垫圈 (66) 并废弃。
5. 如果需要，通过轻轻地将齿圈从盖上撬起，或者通过拆下环形齿轮销 (68)，将固定齿圈 (67) 与齿轮箱盖 (69) 分离。废弃环形齿轮销并用新的更换。
6. 以组件形式收回行星架 (54) 和齿轮。然后可拆下行星架。
7. 除非维修需要，请勿从行星架或行星齿轮拆下滚针轴承 (63A) 或 (58)。如果拆卸它们，则必须废弃，并用新的更换。
8. 从节流阀轴 (32) 推出节流阀杆定位销 (36)。
9. 从起重机的马达端收回节流阀轴 (32) 并拆下节流阀杆 (35)、节流阀杆止推垫圈 (36A) 和节流阀轴弹簧 (37)。
10. 收回环形齿轮 (52)、动力驱动的链轮 (51A)、环形齿轮轴承 (50) 和行星架轴承 (63C)。
11. 拆下四颗链条导板有头螺钉 (4A)、锁紧垫圈 (4B) 和链条导板 (4)。
12. 拆下链罩 (5)。

■ 链条箱拆卸

■ 织物和金属链条箱拆卸

请参阅图TPC451-3

1. 将底部块移动到最低点，以将链条从箱中拆下。将起重机与气源断开。



警告

- 将起重机与气源断开然后再拆下链条箱。
- 2. 分离连接链节 (91) 并拆下支撑链 (306)。
- 3. 拆下螺母 (303)、锁紧垫圈 (304) 和将安装支架 (301) 连接至起重机的支架螺栓 (302)。
- 4. 以组件形式将容器从起重机拆下。
- 5. 如果需要进一步拆卸，请参考图TPC451-3 以将组件分离成其组成部件。

■ 金属链条箱 HLK-K750-85 拆卸

请参阅图 10552230

1. 将底部块移动到最低点，以将链条从箱中拆下。将起重机与气源断开。



警告

- 将起重机与气源断开然后再拆下链条箱。
- 2. 将链节链 (325) 的短块与起重机侧的凸台断开连接，方法是分离连接链节 (91) 并拆下链节。
- 3. 拆下自防松螺母 (326) 和将安装支架 (317) 连接至起重机的托架螺栓 (324)。
- 4. 以组件形式将容器从起重机拆下。
- 5. 如果需要进一步拆卸，请参考图 10552230 以将组件分离成其组成部件。

■ 清洁、检查和维修

使用以下程序来清洁、检查和维修起重机的部件：

■ 清洁



小心

- 必须更换松动、磨损或在壳体中旋转的轴承。如不遵守该提示将导致额外的组件损坏。
- 请勿使用三氯乙烯来清洁部件。

在溶剂中清洁所有起重机组件（制动盘除外）。在清洁期间，必须仔细地彻底清洁组件，避免损坏组件。使用硬鬃毛刷将有助于清除齿轮和架上累积的尘垢和沉积物。如果轴衬已拆下，则可能必须仔细地从未轴承孔移除旧的 Loctite，并避免损坏配合表面。使用低压力经过滤的压缩空气干燥每个部件。

■ 检查

应当对所有拆下的部件进行检查，确定其是否适宜继续使用。特别注意以下方面：

1. 检查所有齿轮是否存在磨损、裂纹或损坏的齿。
2. 检查所有轴衬是否有磨损、划痕或擦痕。
3. 检查轴是否有因磨损而形成脊形。如果由磨损造成的脊形在轴上显而易见，则更换轴。
4. 检查所有螺纹件，更换螺纹已损坏的部件。
5. 测量制动盘 (79) 的厚度。如果制动盘小于 0.090 in. (2.23 mm) 则以套件形式更换制动盘 (79)。
6. 检查消音器 (20) 和 (31) 是否损坏或者是否有过多尘垢。
7. 检查轴承是否正常旋转以及是否有磨损。如果轴承旋转不畅、存在卡滞或阻碍，或者轴承损坏或过度磨损，则进行更换。
8. 检查制动器驱动器 (73) 和行星齿轮架 (54) 中的制动器驱动器轴承磨损区域是否存在脊或擦痕。如果存在任一种状况，则进行更换。

■ 修理

实际的维修限于在齿轮和轴上去除小毛刺和其他微小表面缺陷。使用细砂布来执行该操作。

1. 必须更换磨损或损坏的部件。请参考适用的部件列表，了解具体的更换部件信息。
2. 检查剩余的所有部件是否存在损坏。更换或维修存在可疑状况的任何部件。更换部件的成本通常比返工的成本要低。
3. 去除轴、孔、销或轴衬上的细小痕迹、毛刺或擦痕。
4. 仔细检查所有齿轮齿，并去除痕迹或毛刺。
5. 抛光所有轴肩的边缘以去除可能在搬运期间造成的细小痕迹。
6. 去除锁紧垫圈造成的所有痕迹和毛刺。
7. 更换所有密封件、O 型环和垫圈。

装配

以下装配说明是针对全面装配起重机组件模块。执行必要的装配步骤以从您拆卸结束的点重新装配起重机。例如：如果以组件形式拆下制动器以触及起重机齿轮，则在重装时不必完全将制动器重新装配。仅执行必要的步骤来将制动器组件重新附接至起重机。

■ 一般说明

请参考“一般维护说明”并另外注意：

1. THLK 起重机由各种模块构成。以下说明将先说明如何装配各个模块，最后说明了如何通过已装配好的模块装配起重机。
2. 当在轴承座中安装轴承时，务必朝着滚针型轴承的戳印端按压。
3. 在安装之前务必清洁和擦拭每个部件（制动器部件除外），并涂上薄油膜。
4. 切勿使用溶剂或任何其他清洁剂清洁密封的轴承。用布或硬鬃毛刷小心地去除尘垢、外部施加的润滑油以及沉积物。

■ 链罩装配

请参阅图MHP1065。

1. 将链罩 (5) 置于壳体 (1) 中。
2. 安装链条导板 (4) 并通过链条导板有头螺钉 (4A) 和锁紧垫圈 (4B) 稍微紧固到位。
3. 在起重机完全装配好之后，紧固有头螺钉。

■ 行星齿轮架装配

请参阅图TPB705-2。

1. 将新的行星齿轮轴承 (58) 压入行星齿轮 (57) 的每个端部。将每个轴承安放在在齿轮表面下方的 1/64 in. (0.5 mm) 处。
2. 将足够量的 Ingersoll Rand 11 号油脂施加到行星齿轮轴承的孔中。确保每个滚针或滚柱得到彻底覆盖。
3. 将行星齿轮架 (54) 直立在手扳压机的台上，让其短毂朝上。
4. 在行星齿轮 (57) 的两个端部以及行星齿轮止推扣环 (60) 和齿轮止推轴承 (59) 上涂覆 Ingersoll Rand 11 号油脂薄膜。使用足够的润滑油以使其将部件固定到位。抵靠行星齿轮 (57) 的每个面放置行星齿轮止推扣环 (60)、齿轮止推轴承 (59) 和第二齿轮止推扣环 (60)。
5. 滑动行星齿轮/止推扣环/止推轴承组件，其中行星齿轮大直径齿轮齿位置朝向行星齿轮架的短毂，进入行星齿轮架的一侧。压入行星轮轴 (61) 以将齿轮组件固定在齿轮架中。
6. 为第二和第三行星齿轮组件重复步骤 4 和 5。
7. 将足够量的 Ingersoll Rand 11 号油脂施加到制动器驱动器轴承 (63A) 的孔中，确保每个滚针或滚柱得到覆盖。将制动器驱动器轴承 (63A) 压入行星架 (54) 毂的孔中。将轴承安放在在毂的表面下方的 3/16 in. (5 mm) 处，并进入行星架 (54) 毂的中心。
8. 安装新的制动器驱动器密封件 (63B)，盖朝向轴承 (63A)。
9. 将行星架固定器 (62)、行星架密封件 (65) 和甩油环 (63) 置于行星架 (54) 毂上。在毂上安装行星架垫片 (64)。
10. 确保扣环安装在行星架轴承 (63C) 上。将轴承完全压至行星架 (54) 毂上。确保扣环的位置和朝向行星架的轴承边缘之间为最短距离。
11. 定位行星齿轮架 (54) 使得行星齿轮 (72A) 或 (72B) 可在行星架组件的马达侧安装，其中可触及制动器侧以进行正确的正时标记对齐检查。

12. 请参阅图MHP0569。旋转三个行星齿轮，直至末端的“X”的位置都朝向行星架 (54) 的中心。行星齿轮 (57) 上的正时标记 (‘ ’) 必须位于外部露出的齿轮花键的中心线上。

⚠ 小心

- 很重要的一点是，行星齿轮 (57) 和环形齿轮 (52) 在行星架组件插入环形齿轮时正确对齐。

行星齿轮正时标记布置

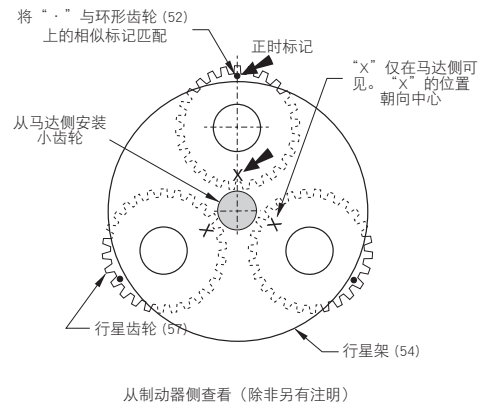

(图MHP0569)

13. 安装行星齿轮 (72)，其中小齿轮的齿进入每个标记了“X”的行星齿轮 (57) 空间。行星齿轮内部花键的位置必须朝向带轂的行星架的末端（制动器端）。
14. 确保扣环安装在行星架轴承 (56) 上。将行星架垫片 (55) 置于行星架轴承 (56) 上。将垫片安装在轴承侧，在扣环和轴承端部之间具有最大间隙。将轴承组件压入行星架 (54)，首先是垫片 (55)，直至垫片和扣环与架齐平。
15. 润滑密封件 (53) 并将其压入环形齿轮 (52) 的端部。
16. 用 Ingersoll Rand 11 号油脂润滑行星齿轮和环形齿轮 (52) 上的齿轮花键和齿。将行星齿轮 (57) 上的“ ”配合标志与环形齿轮 (52) 上的“ ”配合标志对齐，并将行星架组件置于环形齿轮 (52) 中。
17. 要在起重机中进行安装，请参考“起重机组件”部分。

■ 马达组件

请参阅图TPB703-3。

1. 垂直地将马达轴 (38) 固定在铜包虎钳夹中，使得短花键端朝上。
2. 将前端板轴承 (47) 按压到前端板 (46) 中，并将后端板轴承 (40) 按压到后端板 (41) 中。将油脂施加至两个轴承。
3. 滑动前端板和轴承，先是轴承侧，在马达轴上方向下，直至其抵靠马达轴肩部安放。
4. 滑动转子 (42)，显示埋头孔端部，在马达轴上方向下，直至其接触前端板。
5. 用 SAE 10 或 SAE 20 未净化的机油润湿每个叶片 (43)，并将叶片置于转子 (42) 中的每个槽。
6. 将气缸 (44) 安放在转子上，将气缸中的定位销孔与前端板 (46) 中的定位销孔对齐。
7. 滑动后端板 (41) 和轴承 (40) 组件，先是板平坦侧，滑动到马达轴的毂上，直至其接触气缸。将后端板中的定位销孔与气缸中的定位销孔对齐。
8. 在马达轴 (38) 端部的环形凹槽中安装马达后扣环 (39)。
9. 将 1/8 in. (3 mm) 的钢质导向杆插入端板和气缸中的定位销孔约 12 in. (305 mm)，以保持部件对齐，并从虎钳上拆下组件。
10. 要在起重机中进行安装，请参考“起重机组件”部分。

■ 制动器组件

请参阅图TPB704-3。

1. 以 O 型环润滑油轻轻涂覆活塞密封件 (84) 和 (85)，并将它们安装在其在制动器活塞 (83) 上的相应凹槽中。
2. 注意不要切割密封件，不要将活塞滑动到制动器弹簧和活塞壳体 (80) 中。
3. 将弹簧和活塞壳体置于工作台上，其中三个弹簧腔朝上。
4. 将弹簧 (81) 置于每个腔中。
5. 对于新型压力板 (82)：安装压力板螺钉 (82A)，使得螺钉头配合压力板表面上的埋头孔。将压力板 (82) 和螺钉置于弹簧上方，使得螺钉进入制动器活塞中的孔。
对于带有一体螺栓的旧式压力板：将压力板安装在弹簧上方，先是螺栓侧，使得螺栓进入制动器活塞中的孔。

注意

- 为了改善制动器控制，建议将旧式压力板更换为新式压力板 (82) 和螺钉 (82A)。旧式压力板没有提供更换部件。要进行更换，请订购制动器套件编号 MLK-ABK1。
6. 小心地将组件置于虎钳中并对着制动器弹簧及活塞壳体压缩压力板，直至螺钉突起穿过活塞。将活塞螺母 (82B) 旋至螺钉上达至少两个螺纹长度，但是不至于完全接合螺母。
 7. 缓慢地将组件从虎钳中释放。
 8. 对于新式压力板：紧固压力板螺钉 (82A) 及活塞螺母 (82B)，直至压力板及活塞之间存在 0.006 至 0.012 in. (0.15 至 0.30 mm) 的间隙。请参阅图MHP0488。

注意

- 当进行调节时，活塞 (83) 组件应当在活塞螺母 (82B) 和压力板 (82) 之间自由浮动。确保活塞自由地在螺母和压力板之间移动。

对于旧式压力板：将活塞螺母旋至扭矩 50 至 70 英寸磅 (6 至 8 Nm)。

注意

- 确保活塞完全地延伸穿过弹簧和活塞壳体并接触压力板。
9. 将板 (87) 安装在弹簧和活塞壳体 (80) 的凹陷部中并使用两颗板螺钉 (88) 固定。
 10. 要在起重机中完成制动器安装，请参考“起重机组件”部分。

制动器弹簧和活塞壳体组件

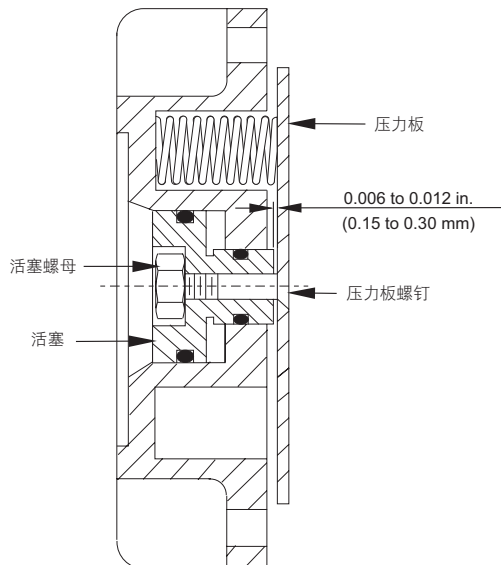

(图MHP0488)

■ 阀门室组件 (新式)

T本程序描述了起重机上使用的阀门室的装配，这些起重机序列号的第二个字母并非 A 至 G 中的一个，或者序列号的第二个和第三个字母并非 HA、HB 或 HC，还描述了已通过阀门室套件编号 MLK-K545B 更新的起重机阀门室。更换部件编号列在部件部分。

请参阅图TPA958-1。

1. 如果阀门室盖销 (17) 被拆下，则将它们安装在阀门室 (6) 的底部。
2. 将 O 型环润滑油的薄膜施加至阀门密封件 (7A) 和 (8A) 并将它们安装在阀门 (7) 和 (8) 上。



- 请勿对阀门密封件替换任何其他 O 型环。

3. 在每个阀门的非锥形端上安装阀门弹簧 (9)，并插入阀门。先是阀门弹簧，进入阀门室的底部的开口。确保标记了“U”的阀门插入标记了“向上阀门”的开口，并且标记了“D”的阀门插入了标记了“向下阀门”的开口。
4. 将 O 型环润滑油的薄膜施加至阀座轴密封件 (10B)。在每个阀座 (10) 中安装密封件。
5. 将 O 型环润滑油的薄膜施加至阀座密封件 (10A) 并在每个阀座上安装两个密封件。
6. 将阀座的较小直径的交叉孔与阀座锁紧螺钉 (11) 的阀门室侧中的螺纹孔对齐。在毂末端拖尾的情况下，将阀座安装在阀门室中。
7. 将阀座锁紧螺钉旋入阀门室。确保它们进入阀座。将螺钉旋至扭矩 24 in lb (3 Nm)。
8. 使用扣环钳并将压力施加至阀座的毂，安装阀座固定器 (12)。确保固定器位于阀门室的凹槽中。
9. 如果活塞 (14) 与活塞轴 (15) 分离，将 O 型环润滑油的薄膜施加至每个活塞轴密封件 (15A) 并将它们安装在活塞轴的凹槽中。
10. 将活塞滑动到活塞轴上，其中活塞的较小毂朝向轴的最小直径。将每个活塞中的交叉孔与每个轴中的交叉孔对齐，然后安装活塞定位销 (15B)。
11. 将 O 型环润滑油的薄膜施加至活塞密封件 (14A) 并在每个活塞上安装一个密封件。
12. 将 O 型环润滑油的薄膜施加至活塞气缸壁上并对着阀座固定器将活塞弹簧 (13) 插入阀门室。
13. 将已装配的活塞和轴安装在阀门室中。
14. 将 O 型环润滑油的薄层施加至阀门室盖密封件 (18A) 并将它们安装在阀门室盖 (18) 中。
15. 将阀门室盖垫圈 (16) 与阀门室盖销对齐并抵靠阀门室放置垫圈。
16. 将阀门室盖与阀门室盖销和活塞轴对齐，并抵靠阀门室放置盖。
17. 安装六个阀门室盖螺钉 (22)。均匀紧固螺钉并旋至扭矩 72 in lb (8 Nm)。
18. 将调节螺钉防松螺母 (21) 旋至减压调节螺钉 (19) 并将螺钉安装在阀门室盖中。

注意

- 使用这些螺钉通过控制板控件调节起重机。请参阅“安装”部分中的“控制板调节”。

19. 当活塞轴组件安装在阀门室中时，手动向上和向下操作活塞轴。活塞轴必须顺畅移动，没有部件受阻的迹象。

■ 阀门室组件 (旧式)

本程序描述了起重机上使用的阀门室的装配，这些起重机序列号的第二个字母为 A 至 G 中的一个，或者序列号的第二个和第三个字母为 HA、HB 或 HC 中的一个。请参阅图 TPA883-3。

注意

- 该阀门室的更换部件不再提供。如果已无法维修，订购套件编号 MLK-K545B (03835519) 来更换该型号阀门室。提供了以下组件说明，仅供参考。
- 用 O 型环润滑油润湿阀门套筒密封件 (326) 并将它们安装在阀门套筒 (325) 上。

小心

- 在安装阀门和阀门套筒组件 (325) 时，确保阀门不会被弄混。这些是以匹配套件的形式装配。

注意

- 每个阀门套筒在一个末端有凹口，并在套筒的壁上有 7/16 英寸 (11 mm) 直径的口。在阀门室内部，存在 7/16 英寸 (11 mm) 直径的交叉口，连接至两个阀门室。
- 插入阀门套筒，首先是有凹口的端部，进入阀门室，使得每个套筒中的 7/16 in. (11 mm) 直径的口与阀门室中的交叉口对齐，并使得套筒中的凹口彼此相对。
 - 将阀门室向上置于入口上并插入阀门弹簧 (327) 和阀门 (325) 至每个阀门套筒中。确保每个阀门进入其相应的套筒。这些为匹配的套件。
 - 用 O 型环润滑油润湿每个活塞密封件 (331) 并将密封件安装在每个活塞 (330) 上的凹槽中。
 - 将每个活塞杆 (328 和 329) 插入，首先是小端，穿过其在活塞中的相应孔。
 - 在每个活塞杆上安装活塞螺母 (332)。紧固螺母至适贴配合。
 - 用 O 型环润滑油润湿阀门室盖密封件 (335) 并将它们安装在阀门室盖 (334) 中。
 - 定位阀门室盖，使得减压孔和调节螺钉 (336) 面向您。用 O 型环润滑油润湿活塞杆的较大直径。从阀门室盖的垫圈侧将较长的活塞杆 (328) 插入穿过左侧的孔。从垫圈侧将较短的活塞杆 (329) 插入穿过右侧的孔。
 - 将活塞弹簧 (333) 置于阀门室中的每个阀门腔体中，并将阀门室盖垫圈 (338) 定位在阀门室的底部。
 - 小心不要捏夹活塞密封件，将阀门室盖安装至阀门室的底部。进行检查，确保长柄活塞杆 (328) 安装在阀门室垫圈面上标记的“向上阀门”侧中。一次性稍微均匀地紧固阀门室盖螺钉 (339)，直至将所有螺钉拧紧。

■ 起重机装配

- 如果进行了拆卸，将新的节流阀轴轴承 (2) 安装在壳体中，并施加薄油脂涂层。
- 在壳体中安装 O 型环密封件 (51)。
- 在壳体中安装链罩 (5)。
- 在输出环形齿轮 (52) 中安装新油密封件 (53)，其中盖朝内。向盖涂覆油或油脂薄膜。
- 确保扣环位于轴轴承 (50) 上。将轴承安装在环形齿轮 (52) 上，其中扣环端部位置朝向环形齿轮。
- 用 Ingersoll Rand 11 号油脂润滑环形齿轮 (52) 轴和链轮 (51A) 上的齿轮花键。在环形齿轮轴上安装链轮。7. 将轴轴承 (49) 安装到环形齿轮 (52) 上。
- 在壳体中安装环形齿轮 (52) 组件。
- 安装链条导板 (4)、四颗链条导板有头螺钉 (4A) 和锁紧垫圈 (4B)。

- 将马达固定器垫圈 (48) 插入在壳体中。升起的外直径应当朝向壳体的开口/马达端。
- 将马达组件安装在壳体中，方法是将马达导向杆和壳体底部中的定位销孔对齐，并将马达滑动到壳体中。
- 拆下导向杆并将其更换为气缸定位销 (45)。定位销的渐缩端必须先进入。定位销应当定位在后端板 (41) 表面下方的大约 1/8 in. (3 mm) 处。
- 将壳体垫圈 (3) 置于起重机的马达端并安装阀门室板 (28) 和螺钉 (30)。用手检查马达轴 (38) 是否自由转动而没有卡滞或阻碍。
- 注意环形齿轮 (52) 和三个行星齿轮 (57) 上的配合标志 “ ”。行星架组件必须插入起重机，使得行星齿轮 (72) 内部花键与马达轴 (38) 花键对齐。另外，行星齿轮上的配合标志 “ ” 必须和环形齿轮上的配合标志 “ ” 对齐。
- 将齿轮箱垫圈 (66) 置于壳体的端部，其中垫圈孔和空气口对齐。
- 如果进行了拆卸，将固定环形齿轮 (67) 和环形齿轮销 (68) 安装在齿轮箱盖中。
- 安装齿轮箱组件，其中起重机上的垫圈和环形齿轮柱形插销和制动器口对齐。安装四个螺栓和锁紧垫圈。
- 安装制动器驱动器 (73)、制动器密封件 (75)、制动器密封件固定器 (74) 以及制动器驱动器固定器螺钉 (76)。将少量的硅密封剂施加至 O 型环。制动器驱动器固定器螺钉是自锁紧型螺钉，只要拆卸了起重机都应当予以更换。将螺钉旋至扭矩 50 in lb (5.65 Nm)。
- 用手检查制动器驱动器是否可自由转动。如果制动器驱动器在两个方向上不能无碍转动，则必须对起重机进行检查，确定卡滞或受阻的原因，然后再进一步装配。
- 如果进行了拆卸，装配上悬架。在吊钩单元上，如“检查”部分中所述，检查吊钩和吊钩锁销。将锁销装配至吊钩。润滑止推轴承 (106)。

对于 HL1000K 至 HL3000K 起重机：

装配吊钩 (102)、止推轴承 (106)、止推垫圈 (107)、吊钩螺母 (104) 和顶部轭架 (101)。务必安装柱形插销 (105) 以在吊钩上锁定吊钩螺母。使用润滑的有头螺钉以及有头螺钉下方的锁销，将顶部轭架组件或耳安装套件安装至起重机。将有头螺钉旋至扭矩 75 - 125 ft lb (100 - 170 Nm)。在有头螺钉平头上方弯曲锁销以进行固定。

对于 HL4500K 和 HL6000K 起重机：

润滑止推轴承 (131)。装配吊钩 (127)、止推轴承、吊钩螺母 (129) 和上悬架壳体 (101)。务必安装吊钩销 (130) 以在吊钩上锁定吊钩螺母。使用润滑的有头螺钉以及有头螺钉下方的锁销，将顶部轭架组件或耳安装套件安装至起重机。将有头螺钉旋至扭矩 75 - 125 ft lb (100 - 170 Nm)。在有头螺钉平头上方弯曲锁销以进行固定。

- 将节流阀轴弹簧 (37) 置于节流阀杆 (35) 毂的上方，其中弹簧的弯曲脚位于节流阀杆的外侧。
- 将节流阀杆固定在凹陷部轮下方的壳体凹陷部中，其中杆的弯曲端朝向起重机的阀门室端，并且节流阀轴弹簧的脚部接合链条导板上的肋。插入节流阀轴 (32)，首先是圆端，穿过阀门室板、壳体和节流阀杆。抵靠节流阀杆的毂安装止推垫圈 (36A)。抵靠节流阀轴弹簧安装止推垫圈 (36A)。安装节流阀杆固定销 (36)。

注意

- 在起重机型号 HL4500K 和 HL6000K 上，节流阀杆 (35) 可能需要调节，以和上悬挂块之间保持足够间隙。可接受对于节流阀杆进行细小修改以形成节流阀杆间隙。
- 将起重机竖直地立在制动器端上。将阀门室垫圈 (25) 置于阀门室板上，确保较小的挡板正确地定位在两个端口之间的凹陷部中。

警告

- 如果阀门室垫圈 (25) 安装不当, 较小挡板将不会位于两个端口之间的凹陷部中。制动器将不会释放, 并且可能导致起重机电机损坏。

- 将两个圆形橡胶盘置于阀门室板内的相应凹陷部中。
- 将已装配的阀门室 (6) 置于阀门室垫圈上。使用阀门室螺钉 (26) 和 (27) 进行固定。
- 如“初始链条安装”部分中所述, 安装起重机电机载荷链。
- 重新定位起重机, 让制动器端朝上。在制动器驱动器 (73) 上方, 放置制动器板 (78), 然后是制动盘 (79)、制动器板 (78)、制动盘 (79) 以及两个制动器板 (78), 将制动器板中的凹口与齿轮箱盖 (69) 中的螺栓孔对齐。
- 重新定位起重机, 让制动器端朝上。安装已装配的制动器弹簧和活塞壳体 (80), 确保 O 型环 (77) 安装在空气口上。安装四颗肩部螺栓 (89) 和锁紧垫圈 (90)。
- 将限制执行器 (33) 置于节流阀轴的方头上, 并安装限制执行器固定销 (34)。
- 对于序列号的第二个字母并非 A 至 G 中的一个、或者序列号的第二个和第三个字母并非 HA、HB 或 HC 的新式起重机, 在限制执行器和阀门轴之间安装两个控制板链节 (183)。
- 对于序列号的第二个字母为 A 至 G 中的一个、或者序列号的第二个和第三个字母为 HA、HB 或 HC 的带控制板的旧式起重机, 在限制执行器和长活塞杆之间安装控制板链节 (183)。
- 对于序列号的第二个字母为 A 至 G 中的一个、或者序列号的第二个和第三个字母为 HA、HB 或 HC 的带拉动链控件的旧式起重机, 无需控制板链节。
- 将 O 型环润滑油的薄膜施加至旋转入口密封件 (24A)。在入口螺栓 (24) 凹槽上安装密封件。
- 小心地将入口螺栓推入入口主体 (23)。小心不要切割密封件。
- 将 O 型环润滑油的薄膜施加至旋转入口垫圈 (24B)。在入口螺栓上安装垫圈。
- 将入口组件装入阀门室顶部并紧固。
- 按照润滑部分中的说明向齿轮箱加注油。

控制板安装

请参阅图 TPA0882-3。

小心

- 将起重机与气源断开连接, 然后再于本起重机上执行维护。

当在 HLK 起重机上安装控制板组件时, 必须使用压线工具 (部件编号 ML50K-930AT 或带凹槽尺寸 G 的 Nicopress 工具) 来将夹紧套筒 (176) 安装在抗拉电缆 (175) 的端部。

抗拉电缆 (175) 必须足够长以允许控制板软管接近笔直地悬挂, 也足够短, 从而能够吸收控制板重量和力。

小心

- 确保抗拉电缆支撑控制板。请勿让控制板软管支撑控制板的重量。软管故障可导致人身伤害以及起重机丧失控制。

注意

- 如果将控制软管切割到一定长度, 在控制板背部的软管 (用于空气进入) 应当延伸超出顶部夹紧套环 6 in. (150 mm)。

根据在起重机上使用的是哪个阀门室, 在手柄前方的两根软管的长度将变化。

- 在新式 MLK-A545A 阀门室上, 软管应当延长超出顶部夹紧套环 (177) 达 2 in (51 mm)。请参阅图 TPB767。
- 在旧式 MLK-A545 阀门室上, 软管应当延长超出顶部夹紧套环 (177) 达 4 in (100 mm)。请参阅图 TPB766。
- 将一个软管夹 (218) 安装在控制板手柄 (160) 上方, 并将一个软管夹安装在夹紧套环 (177) 下方。在手柄和套环上的软管夹之间每隔 2-1/2 英尺 (0.76 m) 安装剩余软管夹。
- 安装警告标记, 使得标记可由操作员从控制板手柄的杆侧看到。

新式阀门室连接

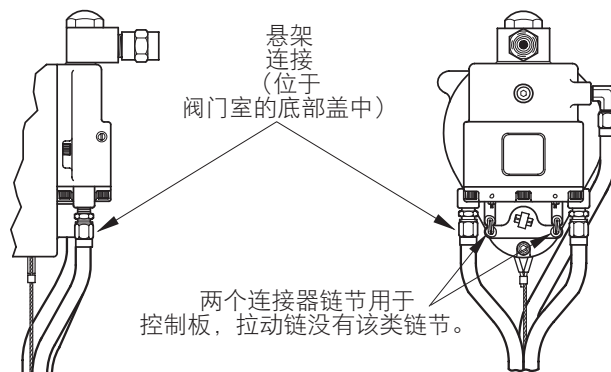

(图 TPB767)

旧式阀门室连接

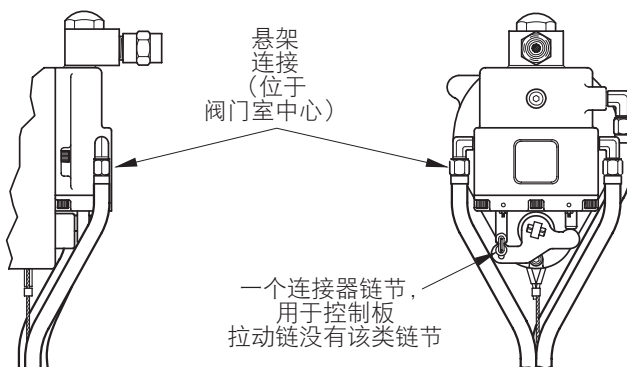

(图 TPB766)

链条箱

安装织物和金属链条箱

请参阅图 TPC451-3

- 在链开口区域内起重机底部的凸台之间定位安装支架 (301)。
- 从链条箱内部插入两颗支架螺栓 (302), 穿过安装支架和凸台。支架螺栓头部应当接触安装支架。
- 将垫圈 (304) 和支架螺母 (303) 置于每个支架螺栓之上。

注意

- 如果允许容器向外摆动, 则将支架螺母 (303) 紧固为差一圈完全拧紧。这将允许容器从载荷向外摆动。
- 由于空间限制, 可能必须压下节流阀杆 (35) 以将支架螺栓 (302) 安装在配备了手动链条节流阀的起重机上。配备控制板节流阀的起重机可能需要拆下控制板链节 (183) 方可安装支架螺栓。在安装支架附接至起重机之后, 重新安装控制板链节。
 - 将支撑支架 (305) 紧固至链条箱的外部, 其中支架螺母和垫圈定位在链条箱的外部。
 - 以相同方式将链条箱紧固至安装支架。
 - 小心地拆卸链锚固件 (91) 并将支撑链 (306) 的一个端部附接至带载荷链 (92) 的链锚固件。

小心

- 确保当把支撑链附接至链锚固件时，载荷链不会变扭曲。
8. 使用支撑支架螺栓 (307)、支撑支架垫圈 (309) 和支撑支架螺母 (308) 将支撑链的自由端紧固至支撑支架。

注意

- 在支撑支架调节支撑链，以防止在操作起重机时，载荷链摩擦容器。

安装金属链条箱 HLK-K750-85

请参阅图 10552230

T以下说明用于将 HLK-K750-85 金属 链条箱套件添加至标准起重机。

1. 运行底部块至最低点以访问起重机上的安装区域。将起重机与气源断开。

警告

- 将起重机与气源断开然后再安装链条箱。
2. 在链开口区域内起重机底部的凸台之间定位链条箱 (318)。附接支架 (317) 至起重机主体。从链条箱内部插入两颗支架螺栓 (324)，穿过安装支架和凸台。支架螺栓头部应当接触安装支架。在螺栓上安装自防松螺母 (326)。
 3. 使用链节 (91) 将链节链 (325) 的短块附接至起重机侧上的凸台。
 4. 在载荷链的端部附近附接链止挡组件 (319)。参阅 HLK-K750-85 链止挡布置图示。
 5. 检查控制杆是否正常工作。

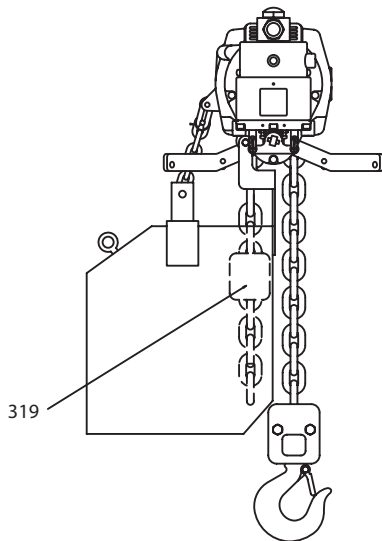
HLK-K750-85 链止挡布置

(图MHP4303)

注意

- 操作起重机以自然地将链条堆放到链条箱中。用手不当地将链条堆放到箱中可能导致打结和扭曲，从而可能导致链条卡住起重机。
6. 紧固所有螺钉。将气源提供至起重机，并将链条运行到箱内。

■ 载荷测试

在初次使用之前，所有新的、大范围修理过的或改动的起重机，都将在本起重机的安全、维护和操作中说明的人员的指导下进行载荷测试。必须保留书面报告记录，确认起重机的额定值。

1. 以两个方向完全操作起重机而不带载荷。起重机必须顺畅运转，没有受阻迹象。对于控件操作的响应必须迅速而准确。
2. 将 10% 载荷置于起重机上并完全地以两个方向操作起重机。起重机必须顺畅运转，没有受阻迹象。对于控件操作的响应必须迅速而准确。
3. 动态地对起重机进行载荷测试，最高达到其额定容量的 100%。起重机必须顺畅运转，没有受阻迹象。对于控件操作的响应必须迅速而准确。

注意

- 要在额定容量 100% 以上进行测试，可能必须遵守美国以外地区制定的标准和规定。

故障排除

本部分介绍故障排除的基本信息。应按照本设备安全、操作和维修说明，由专业人员进行彻底检查以确定问题的具体原因。下表为常见起重机症状、可能的原因及维修方法提供了简要指南。

状况	原因	维修方法
起重机将不工作。	起重机没有气源，或者流量或压力过小。	检查气源管路连接和软管。检查起重机马达入口上的气源。在起重机马达入口，至少需要 70 scfm (1.96 cu. m/m)、90 psig (6.3 bar/630 kPa) 的空气流量，以提供额定的起重机性能。
	起重机过载。	将载荷减小至额定容量以内。
	马达损坏。	拆卸、检查和更换部件。请参考“维护”部分。
	控制板故障。	检查控制板节流阀杆是否自由移动。检查控制板上的空气压力。控制板管路中的最小工作压力必须为 55 psig (3.8 bar/380 kPa)。检查润滑器油位。如果过低则进行填充。
当起重机停止时载荷继续移动（向上方向）。	制动器未释放。	检查制动器释放回路和压力。制动器入口中的最小工作压力必须为 55 psig (3.8 bar/380 kPa)。
	阀门或节流阀杆粘滞。	检查控制板节流阀杆是否自由移动。按需要进行润滑或修理
	倾泄阀未释放。	检查控制板软管倾泄阀。
当起重机停止时载荷继续移动（向下方向）。	控制板杆粘滞。	检查控制板节流阀杆是否自由移动。
	倾泄阀未释放。	检查控制板软管倾泄阀。
	倾泄阀未释放。	检查控制板软管倾泄阀。
	起重机过载。	将载荷减小至额定容量以内。
起重机未提升载荷。	阀门或节流阀杆粘滞。	检查控制板节流阀杆是否自由移动。
	制动器滑动。	检查制动器弹簧以及制动盘摩擦衬片是否有磨损。请参考“维护”部分。
	起重机没有气源，或者流量或压力过小。	检查气源管路连接和软管。检查起重机马达入口上的气源。在起重机马达入口，至少需要 70 scfm (1.96 cu. m/m)、90 psig (6.3 bar/630 kPa) 的空气流量，以提供额定的起重机性能。
	起重机过载。	将载荷减小至额定容量以内。
	主要空气行程受限。	检查节流阀杆和连杆是否自由、顺畅地移动。
速度和/或容量减小。	排放受限制。	检查通风孔并更换消声器。请参考“维护”部分。
	马达损坏。	拆卸、检查和更换部件。请参考“维护”部分。
	入口螺栓 (24) 网已插入，限制空气流量。	用新式入口螺栓 (无网) 更换带网的旧式入口螺栓，或拆下网。
	润滑器油位过低。	加注润滑器。
起重机以降下方向工作但不会起吊。	起重机没有气源，或者流量或压力过小。	检查气源管路连接和软管。检查起重机马达入口上的气源。在起重机马达入口，至少需要 70 scfm (1.96 cu. m/m)、90 psig (6.3 bar/630 kPa) 的空气流量，以提供额定的起重机性能。如“安装”部分中所述，检查控制板调节。
	减压螺钉失调	根据“安装”部分中的“减压螺钉调节”程序中所述，调节减压螺钉。
起重机以起吊方向工作，但是不会降下。	起重机过载。	将载荷减小至额定容量以内。
	制动器活塞密封件泄漏。	安装新密封件。请参考“维护”部分。
载荷链在滑轮上跳动或发出“咔嗒”声。	控制板故障。	检查控制板节流阀杆是否自由移动。检查控制板上的空气压力。控制板管路中的最小工作压力必须为 55 psig (3.8 bar/380 kPa)。
	载荷链上脏污或缺少润滑油。	清洁并润滑载荷链。请参考“润滑”部分。
	磨损或生锈的载荷链。	检查载荷链。请参考“检查”部分。清洁并润滑载荷链。请参考“润滑”部分。
	磨损的载荷滑轮或不当绕上钢丝绳的载荷链。	检查载荷链是否正确绕上钢丝绳。拆卸、检查和更换磨损的部件。请参考“维护”部分。
起重机没有和载荷对齐。	翻转的吊钩。	根据“维护”部分中所述进行修正。
	起重机没有和载荷对齐。	将起重机与载荷对齐。请勿从一侧拉动载物或“堆砌”载物。

HOIST ASSEMBLY DRAWING AND PARTS LIST TABLE OF CONTENTS

Hoist Parts Section Guide (Dwg. TPA884-3)	56
Hoist Housing Assembly Parts Drawing (Dwg. MHP1065)	57
Hoist Housing Assembly Parts List	58
Hoist Valve Chest Assembly Parts Drawing (Dwg. TPA958-1)	59
Hoist Valve Chest Assembly Parts List	60
Hoist Gearing Assembly Parts Drawing (Dwg. TPB705-2)	61
Hoist Gearing Assembly Parts List	62
Hoist Brake Assembly Parts Drawing (Dwg. TPB704-3)	63
Hoist Brake Assembly Parts List	64
Motor Assembly Parts Drawing (Dwg. TPB703-3) and Parts List	65
Top Lug Assembly Drawing (Dwg. TPC449-3) and Parts List	66
HL1000K, HL1000KR and HL1500K Hook Assembly Parts Drawing (Dwg. MHP1105)	67
HL1000K, HL1000KR and HL1500K Hook Assembly and Parts List	68
HL2000K and HL3000K Hook Assembly Parts Drawing (Dwg. MHP1106)	69
HL2000K and HL3000K Hook Assembly Parts List	70
HL4500K Hook Assembly Parts Drawing (Dwg. TPA1041)	71
HL4500K Hook Assembly Parts List	72
HL6000K Hook Assembly Parts Drawing (Dwg. TPA1040)	73
HL6000K Hook Assembly Parts List	74
Pendant Assembly Parts Drawing (Dwg. TPA0882-3)	75
Pendant Assembly Parts List	76
Fabric and Metal Chain Container Assembly Parts Drawing (Dwg. TPC451-3)	77
Fabric and Metal Chain Container Assembly Parts List	78
HLK-K750-85 Metal Chain Container Assembly Parts Drawing (Dwg. 10552230)	79
HLK-K750-85 Metal Chain Container Assembly Parts List 55	80
Repair and Conversion Kits	81
Accessories	82

HOIST PARTS SECTION GUIDE

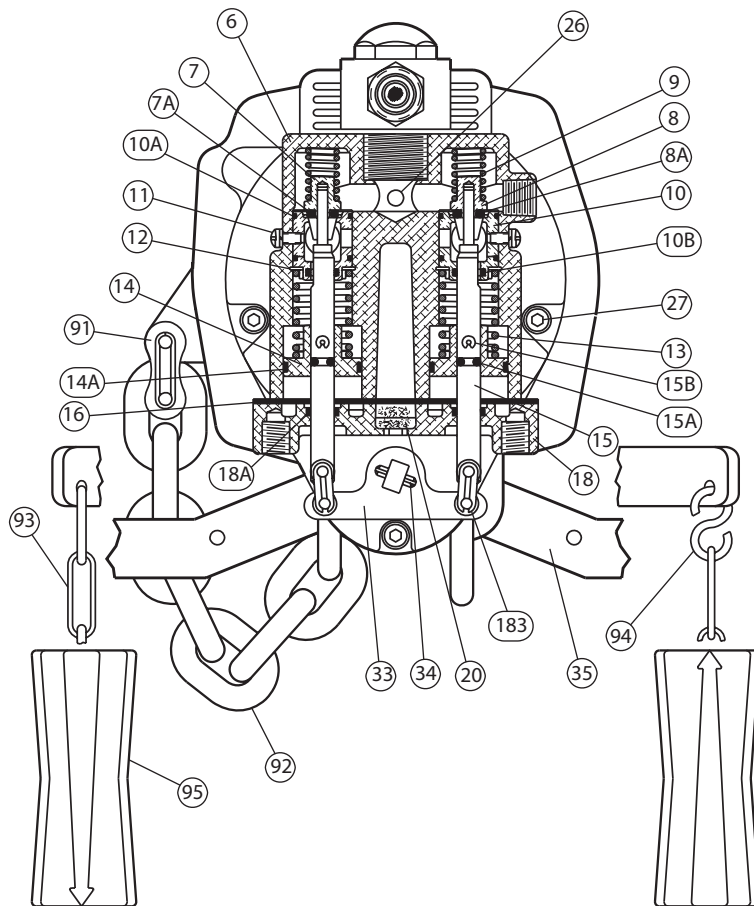
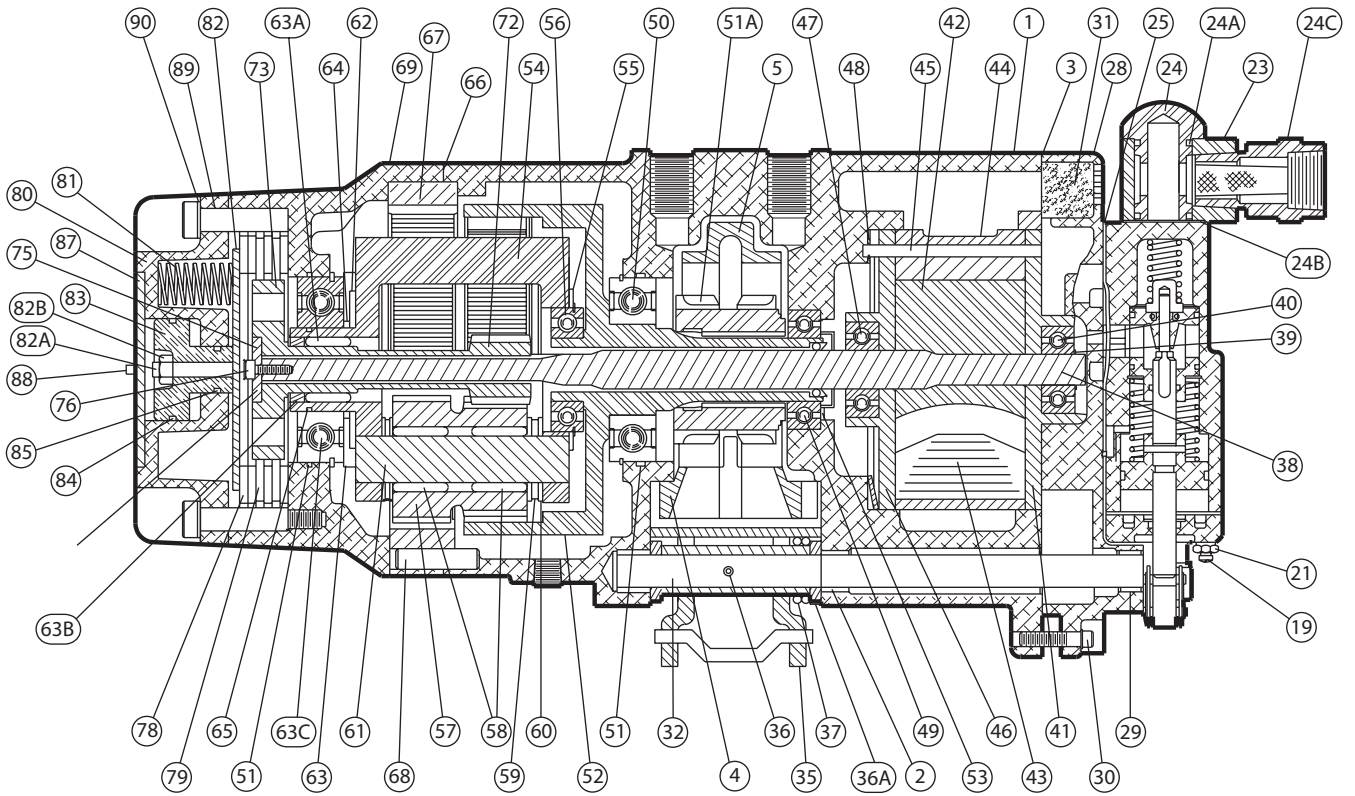

(Dwg.TPA884-3)

HOIST HOUSING ASSEMBLY PARTS DRAWING

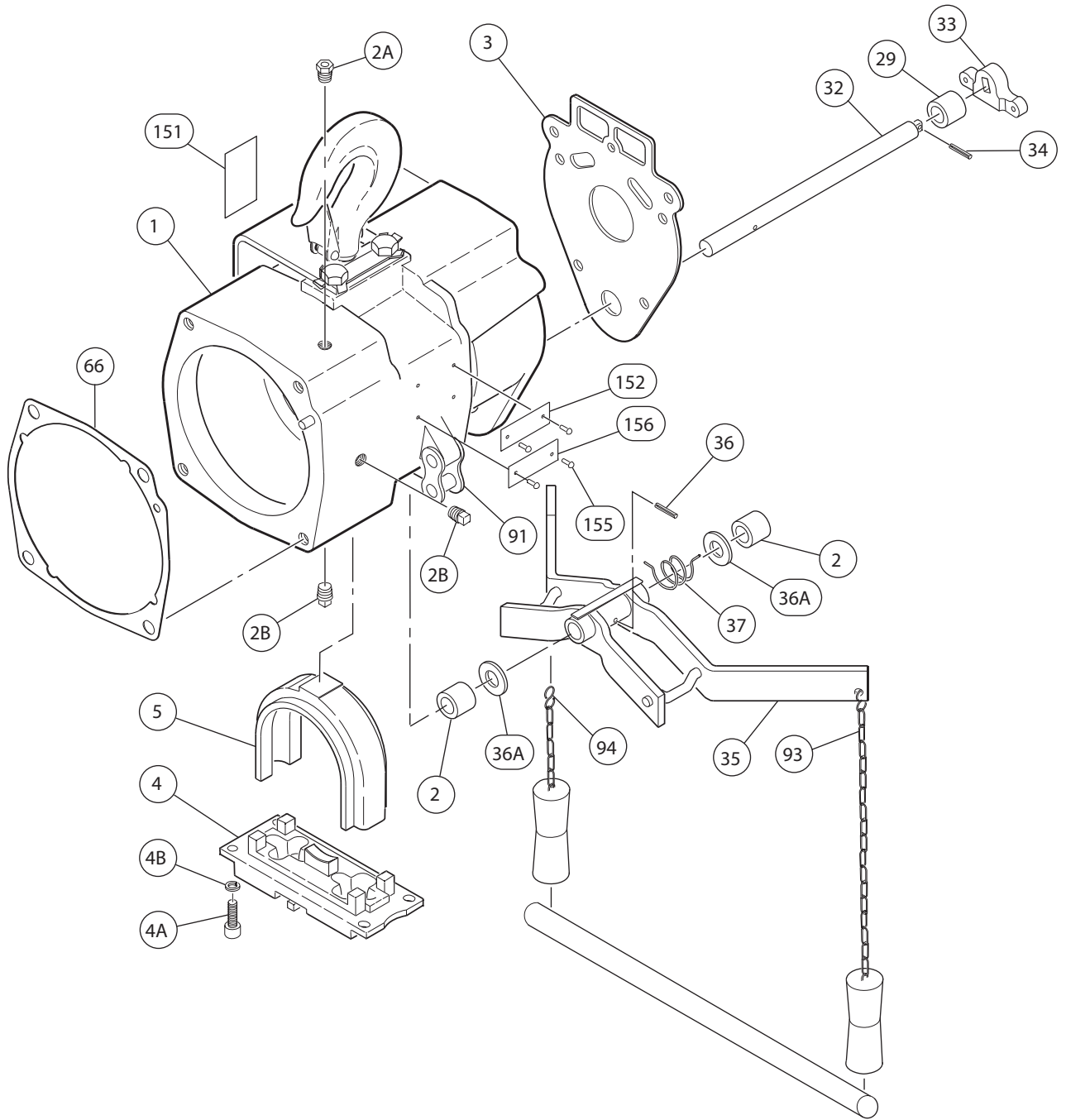

(Dwg. MHP 1065)

HOIST HOUSING ASSEMBLY PARTS LIST

ITEM No.	DESCRIPTION OF PART	QTY	PART NO.
---	Housing Assembly	1	HLK-A300
1	Housing	1	Not sold separately *
• 2	Throttle Shaft Bearing	2	H54U-511
2A	Vent Plug	1	CE210-120
2B	Level and Drain Plug	2	R0H-377
• 3	Housing Gasket	1	ML50K-445
4	Chain Guide	1	HLK-741
4A	Chain Guide Screw	4	G57T-634
4B	Lockwasher	1 Pack of 10	8U-58-10
5	Chain Guard	1	HLK-6
• 29	Throttle Lever Bearing	1	R38M-603
32	Throttle Shaft	1	MHLK-255
33	Limit Actuator (Old Style Hoist) **	1	MLK-251
	Limit Actuator (New Style Hoist) **	1	MLK-251A
34	Limit Actuator Retaining Pin	1	WF171-15
35	Throttle Lever	1	HLK-556
36	Throttle Lever Retaining Pin	1	WF171-15
36A	Throttle Lever Thrust Washer	2	MR-458
37	Throttle Shaft Spring	1	MR-412
66	Gear Case Gasket	1	HLK-31
91	Connecting Link	1	HRA30A-646
93	Standard Pull Chain	Specify Length x	CA110-B240
	HL1000KR Spark Resistant Pull Chain	2	D02-1413
---	Pull Chain Conversion Kit (without Pull Chain) ***	1	MLK-K415A
94	'S' Hook	4	D02-421
96	Plug, Pipe (shown on Dwg. TPA958-1)	1	R0H-377
97	Plug, Vent (shown on Dwg. TPA958-1)	2	P250-546
151	Warning Label	1	04306445
152	Serial Number Label Plate	1	MLK-301S-R
155	Fasteners, Label Plate	4	R4K-302
156	Model Number Label Plate	1	MLK-301M-R

• Recommended Spare

* Housing (1) not sold separately; purchase housing assembly (HLK-A300).

** New Style Hoist references apply to hoists with second letter of the serial number other than A through G or with second and third letters other than HA, HB, or HC.

Old Style Hoist references apply to hoists with second letter of the serial number A through G or with second and third letters HA, HB, or HC.

*** Pull Chain Conversion Kit replaces item 33 (Limit Actuator) on Dwg. MHP1065, items 181 (Fitting, Elbow) and 182 (Fitting Nipple) on Dwg. TPA958-1, and attached pendant (including control hoses).

HOIST VALVE CHEST ASSEMBLY PARTS DRAWING

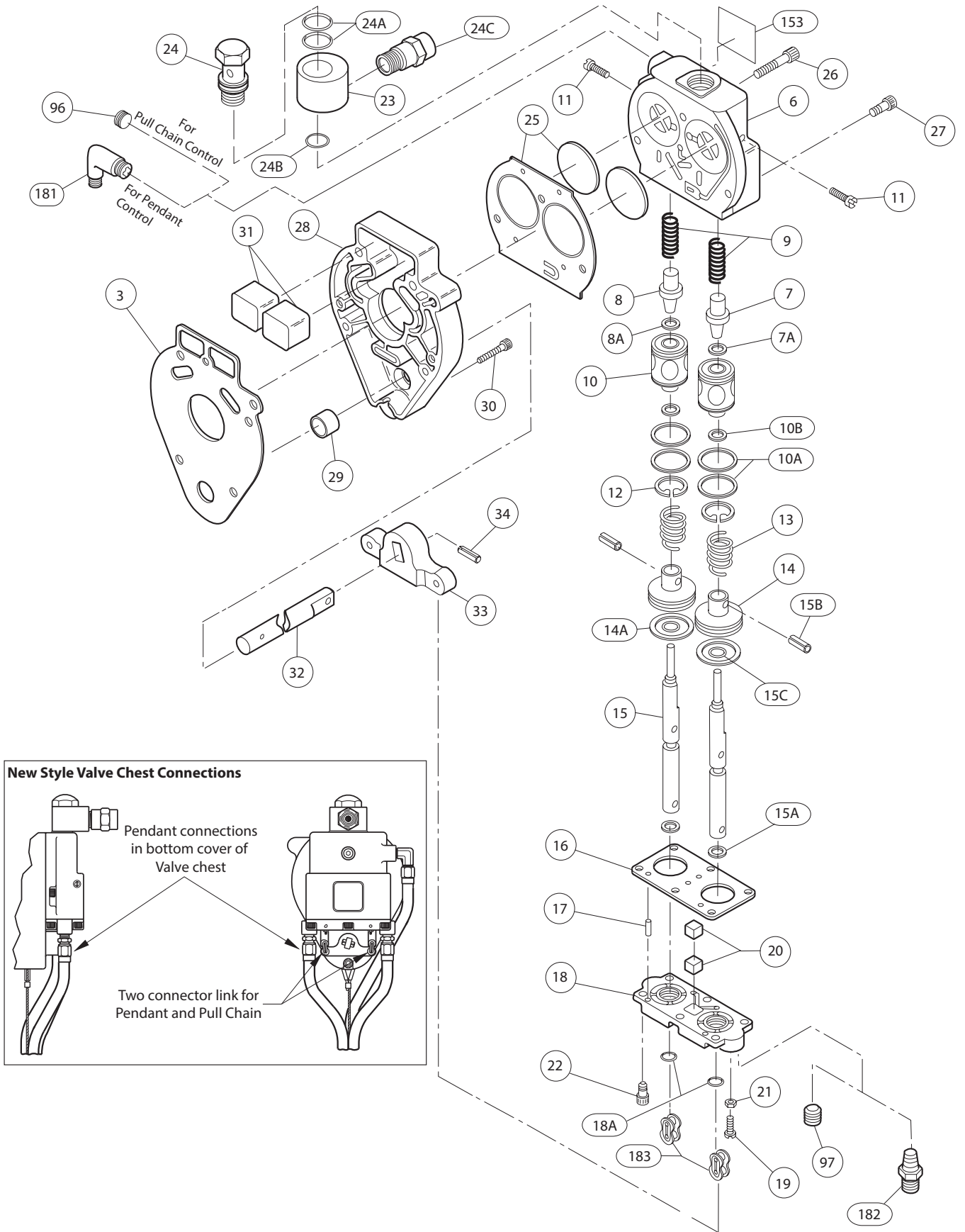

(Dwg. TPA 958-1)

HOIST VALVE CHEST ASSEMBLY PARTS LIST

ITEM No.	DESCRIPTION OF PART	QTY	PART NO.	ITEM No.	DESCRIPTION OF PART	QTY	PART NO.
3	Housing Gasket	1	ML50K-445	22	Valve Chest Cover Screw	6	MLK-240
---	Valve Chest Assembly	1	MLK-A545B	---	Swivel Inlet Assembly	1	MLK-B4
6	Valve Chest	1	MLK-545A	23	Inlet Body	1	MLK-166
• 7	Up Valve Assembly	1	MLK-K102U	24	Inlet Stud	1	MLK-4A
• 7A	Up Valve Seal	1	MLK-211	• 24A	Swivel Inlet Seal	2	R4-210
8	Down Valve Assembly	1	MLK-K1102D	• 24B	Swivel Inlet Gasket	1	R18LF-21
• 8A	Down Valve Seal	1	MLK-211	24C	Inlet Strainer	1	MLK-82
9	Valve Spring	2	MLK-942A	• 25	Valve Chest Gasket	1 Set	MLK-928-80
10	Valve Seat Assembly	2	MLK-K615	26	Valve Chest Screw	1	518-104
• 10A	Valve Seat Seal	2	C321-606	27	Valve Chest Screw	2	R0H-354-4
• 10B	Valve Seat Shaft Seal	1	R000BR-210	28	Valve Chest Plate	1	HLK-549
11	Valve Seat Lock Screw	2	AF160-305	• 29	Throttle Lever Bearing	1	R38M-603
• 12	Valve Seat Retainer	2	MLK-218	30	Valve Chest Plate Screw	5	5080-638-4
13	Piston Spring	2	MLK-250A	31	Muffler	2	MLK-175
14	Piston Assembly	2	MLK-K246A	32	Throttle Shaft	1	MHLK-255
• 14A	Piston Seal	1	HLK-103	33	Limit Actuator (Old Style Hoists) *	1	MLK-251
15	Piston Shaft Assembly	2	MLK-K655A		Limit Actuator (New Style Hoist) *		MLK-251A
• 15A	Piston Shaft Seal	1	R0BR1C-283				
• 15B	Piston Retaining Pin	1	510-669A				
• 15C	'O' Ring	1	Y330-006	34	Limit Actuator Retaining Pin	1	WF171-15
16	Gasket	1	MLK-117A	96	Plug, Pipe (Pull Chain) **	1	R0H-377
17	Pin	2	MLK-241	97	Plug, Vent (Pull Chain) **	2	P250-546
18	Cover Assembly	1	MLK-A238A	153	Ingersoll Rand Logo	1	HRA20A-201
• 18A	Valve Chest Cover Seal	2	R000BR-210	181	Fitting, Elbow (Pendant) **	1	UWD-161
19	Bleed Adjustment Screw	2	MLK-370	182	Fitting, Nipple (Pendant) **	2	MLK-165
20	Muffler	2	MLK-236	183	Link	2	MLK-224
21	Adjustment Screw Locknut	2	Q1-121				

• Recommended Spare

Repair and Conversion Kits

---	Valve Chest Repair Kit For New Style Hoist* only.	1	MLK-VCK1	Includes items 7A, 8A, 9, 10A, 10B, 12, 13, 14A, 15A, 15B, 16, 17, 18A, 24A, 24B, 24C, 25 and 183.
---	Overhaul Gasket Kit for all HLK Hoists (numbers in paranthesis are for Old Style Hoist valve chest parts)	1	HLK-K445	Includes items 3, 7A, 8A, 10A, 10B, 12, 14A, 15A, 15B, 18A (335), 24A, 24B, 25, 34, 36, 39, 'O' ring for 49, 51, 53, 63B, 64, 65, 66, 75, 76, 77, 84, 85, 105, 109, 114, 119, 130, 138, 144, 162, 164, 180, 183 and (331).

* New Style Hoist refererences apply to hoists with second letter of the serial number other than A through G or with second and third letters other than HA, HB, or HC.

Old Style Hoist refererences apply to hoists with second letter of the serial number A through G or with second and third letters HA, HB, or HC.

** Pull Chain Conversion Kit (MLK-K415) provides items 94 through 98 to convert hoist to pull chain operation. Items 33, 181, 182 and attached pendant (including control hoses) are replaced by this conversion. Order Pull Chain (93) separately. Refer to Dwg. MHP1065 parts list for detailed information.

Pendant Conversion Kit (MLK-AL269C) includes all components necessary to convert a pull chain throttle hoist to pendant control operation used on MLK, MLKR, HLK and HLMR hoists. Items 93 through 98 are replaced by this conversion. Length of pendant hose must be specified when ordering. Pendant length is normally 5 ft (1.5 m) shorter than lift. Refer to Dwg TPA0882-3 for additional pendant information.

HOIST GEARING ASSEMBLY PARTS DRAWING

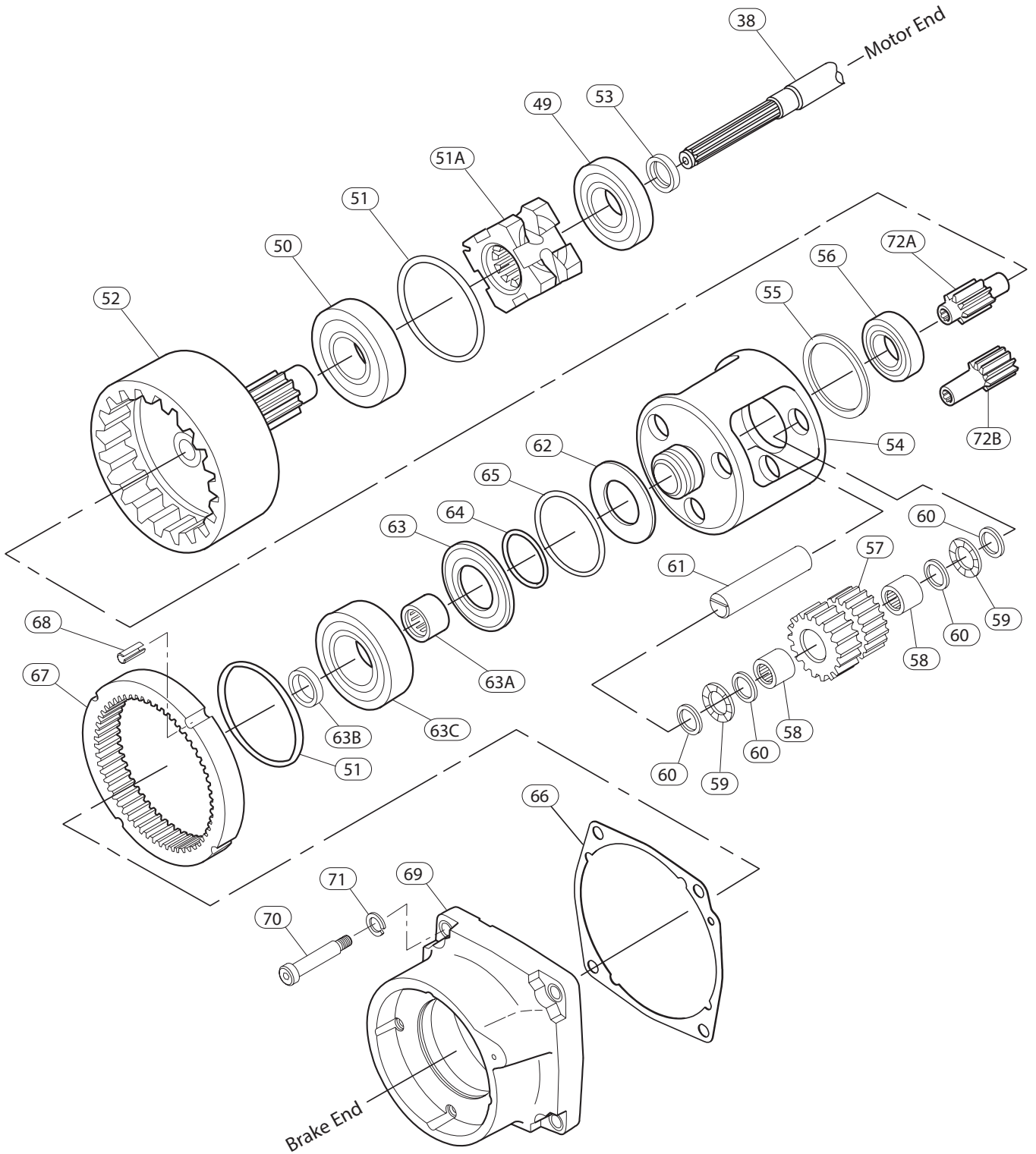

(Dwg.TPB 705-2)

HOIST GEARING ASSEMBLY PARTS LIST

ITEM No.	DESCRIPTION OF PART	QTY	PART NO.	ITEM No.	DESCRIPTION OF PART	QTY	PART NO.
38	Motor Shaft	1	HLK-316	63A	Brake Driver Bearing	1	182A83-606
49	Housing Bearing	1	HRA20A-987	63B	Brake Driver Seal	1	HLK-137
50	Ring Gear Bearing	1	HLK-97	63C	Planet Frame Bearing	1	HLK-97
• 51	'O' Ring	2	HLK-21	64	Planet Frame Spacer	1	R2C-103
51A	Chain Wheel (Powered)	1	HLK-740	65	Planet Frame Seal	1	HLK-103
52	Ring Gear	1	HLK-798	• 66	Gear Case Gasket	1	HLK-31
• 53	Seal	1	HLK-457	67	Fixed Ring Gear	1	HLK-406
---	Planet Frame Assembly	1	HLK-AP8	68	Ring Gear Pin	4	HLK-20
54	Planet Frame	1	HLK-8	69	Gear Case Cover	1	HLK-353
55	Planet Frame Spacer	1	HLK-645	70	Gear Case Screw	4	21-702
56	Planet Frame Bearing	1	HLK-96	71	Lockwasher	4	UW50A30-58
57	Planet Gear Assembly	3	HLK-A10	• 72A	Pinion Gear	1	HLK-319-12
58	Gear Bearing	6	182A83-606		For HL1500K, HL3000K, HL4500K and HL6000K		
59	Gear Thrust Bearing	6	R02W-696				
60	Gear Thrust Race	12	CE210-603	• 72B	Pinion Gear	1	HLK-319-15
61	Planet Shaft	3	HLK-191		For HL1000K, HL1000KR and HL2000K		
62	Planet Frame Retainer	1	HLK-39				
• 63	Oil Slinger	1	HLK-974				

• Recommended Spare

HOIST BRAKE ASSEMBLY PARTS DRAWING

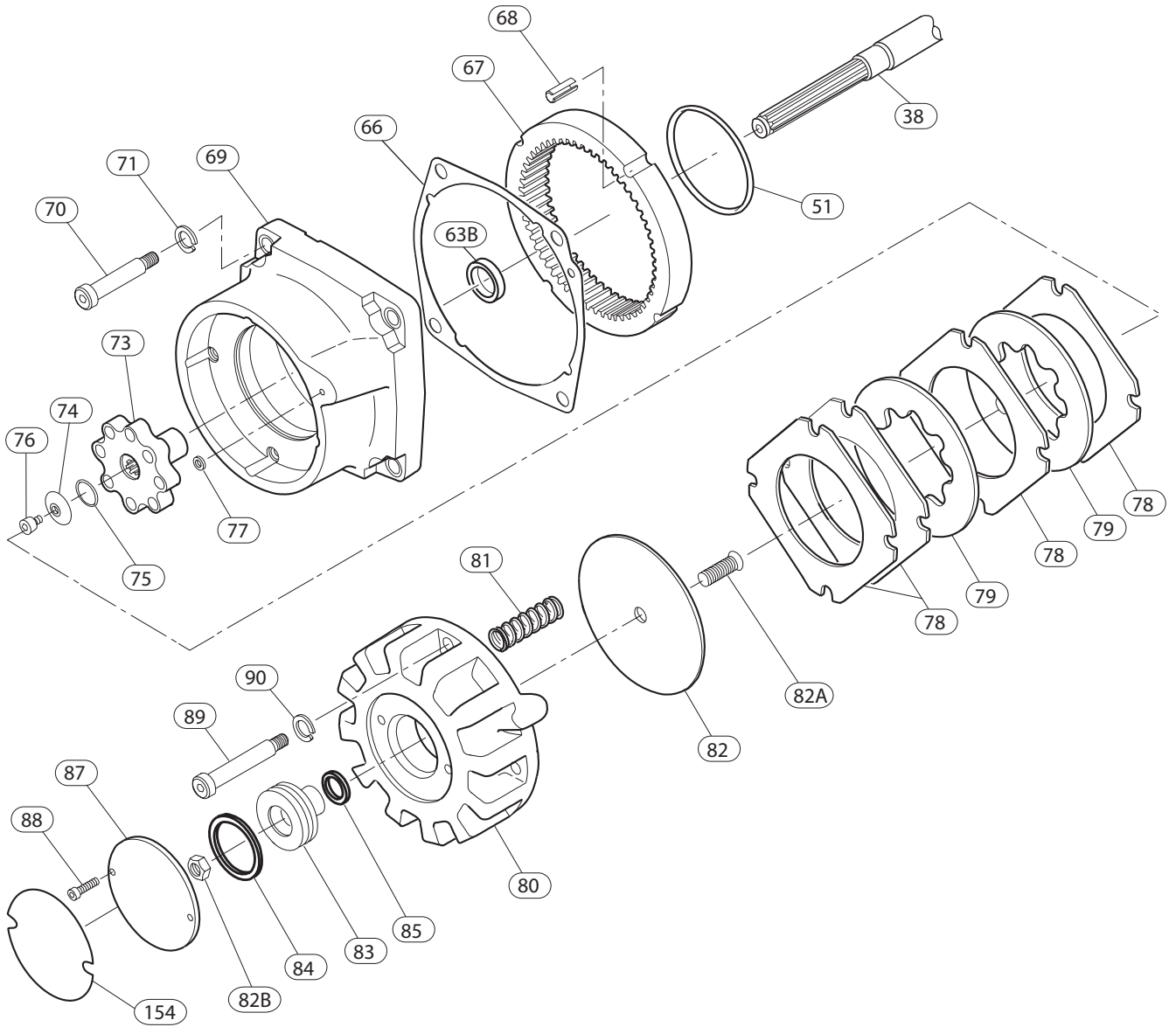

(Dwg.MHP 704-3)

HOIST BRAKE ASSEMBLY PARTS LIST

ITEM No.	DESCRIPTION OF PART	QTY	PART NO.	ITEM No.	DESCRIPTION OF PART	QTY	PART NO.
38	Motor Shaft	1	HLK-316	81	Spring	3	MLK-832
• 51	O-Ring	2	HLK-21	82	Pressure Plate	1	ML50K-K338A
63B	Brake Driver Seal	1	HLK-137	82A	Pressure Plate Screw	1	ML50K-805A
• 66	Gear Case Gasket	1	HLK-31	82B	Piston Nut	1	ML50K-394
67	Fixed Ring Gear	1	HLK-406	83	Piston	1	ML50K-A809
68	Ring Gear Pin	4	HLK-20	• 84	Piston Large Seal	1	R2C-103
69	Gear Case Cover	1	HLK-353	• 85	Piston Small Seal	1	MLK-210
70	Gear Case Screw	4	21-702	87	Plate	1	ML50K-981
71	Lockwasher	4	UW50A30-58	88	Plate Screw	2	CE110-354
• 73	Brake Driver	1	ML50K-842	89	Shoulder Bolt	4	HLK-7
74	Brake Seal Retainer	1	HLK-639	90	Lockwasher (Qty. 10/pack)	1 Pack	D02-321-10
• 75	Brake Seal	1	R18L-14	154	Capacity Labels		
• 76	Retainer Screw	1	HLK-640		HL1000K and HL1000KR (1 ton)	1	ML100K-99
• 77	'O' Ring (Air Port)	1	PS3-67		HL1500K (1-1/2 ton)		HL1500K-99
78	Brake Plate	4	ML50K-834A		HL2000K (2 ton)		HL2000K-99
• 79	Brake Disc	2	ML50K-855A		HL3000K (3 ton)		HL3000K-99
---	Brake Spring and Piston Housing Assembly	1	MLK-A395A		HL4500K (4-1/2 ton)		HL4500K-99
---					HL6000K (6 ton)		HL6000K-99
80	Spring and Piston Housing	1	ML50K-395A				

• Recommended Spare

Repair and Conversion Kits

---	Brake Repair Kit	1	MLK-ABK1	Includes items 79, 81, 84 and 85.
---	Manual Brake Release Kit	1	MLK-K390	Includes all components for a manual release brake.
---	Govt Brake Release Kit	1	MLK-K390H	200% brake capability.

MOTOR ASSEMBLY DRAWING

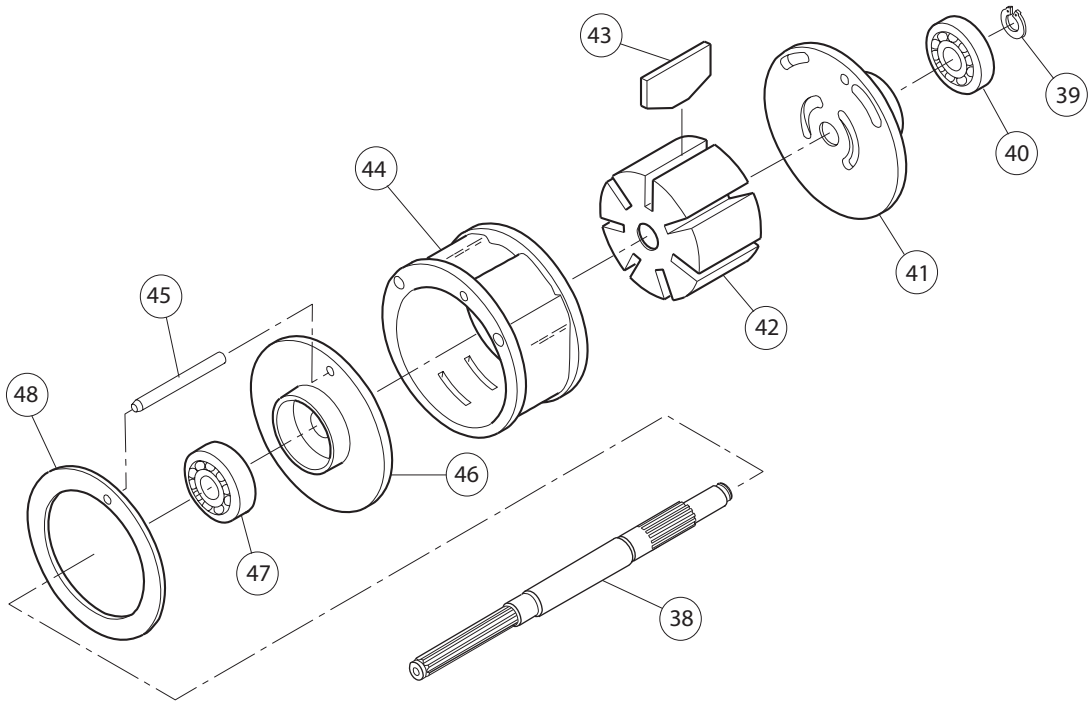

(Dwg.TPB703-3)

MOTOR ASSEMBLY PARTS LIST

ITEM No.	DESCRIPTION OF PART	QTY	PART NO.	ITEM No.	DESCRIPTION OF PART	QTY	PART NO.
---	Motor Assembly	1	HLK-A53	• 43	Vane Packet	set of 7	MR-42-7
38	Motor Shaft	1	HLK-316	44	Cylinder	1	MR-3A
39	Motor Shaft Rear Retainer Ring	1	MLK-120	45	Cylinder Dowel	1	R3H-434
• 40	Rear End Plate Bearing	1	R2-24	46	Front End Plate	1	MR-11
41	Rear End Plate	1	MR-12	• 47	Front End Plate Bearing	1	TB-394
42	Rotor	1	MR-53	48	Motor Retainer Washer	1	MR-207

• Recommended Spare

TOP LUG ASSEMBLY DRAWING AND PARTS LIST

RIGID TROLLEY MOUNT

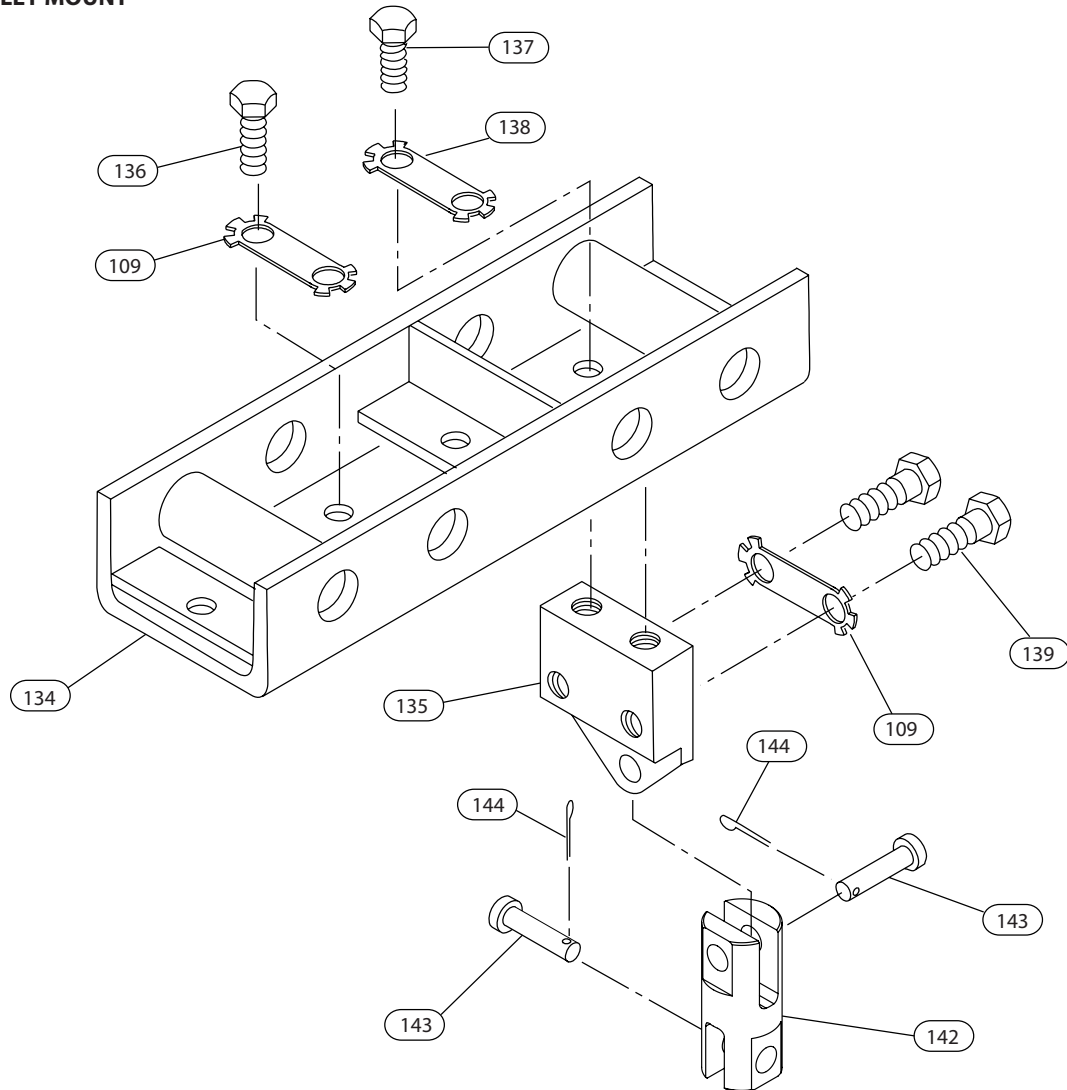

(Dwg.TPC449-3)

ITEM No.	DESCRIPTION OF PART	QTY	PART NO.		
			HL1000K	HL1500K	HL2000K/HL3000K/HL1000KR
	Top Lug Kit	1	HLK-K444A		HL3000K-K444A
• 109	Locking Tab	2	HLK-322		
134	Lug Block	1	HLK-444A		
135	Lug Mounting Block	1	HLK-425		
136	Bolt (1.5 inch long)	2	215-36		
137	Bolt (1.25 inch long)	2	215-13		
• 138	Locking Tab	1	HLK-323		
139	Bolt (2.25 inch long)	2	215-22		
142	Chain Anchor	1	---		HLK-373
143	Pin	2	---		HLK-962
• 144	Cotter Pin	2	---		D02-330

•	Recommended Spare
---	-------------------

Note 1: Torque bolts (items 136, 137 and 139) to between 75 and 125 ft lbs (100 and 170 Nm).

Note 2: The head of pin (item 143) must be located on the motor side of the chain anchor (item 142).

HL1000K, HL1000KR AND HL1500K HOOK ASSEMBLY PARTS DRAWING

Top Hook and Yoke Assembly for HL1000K, HL1000KR and HL1500K

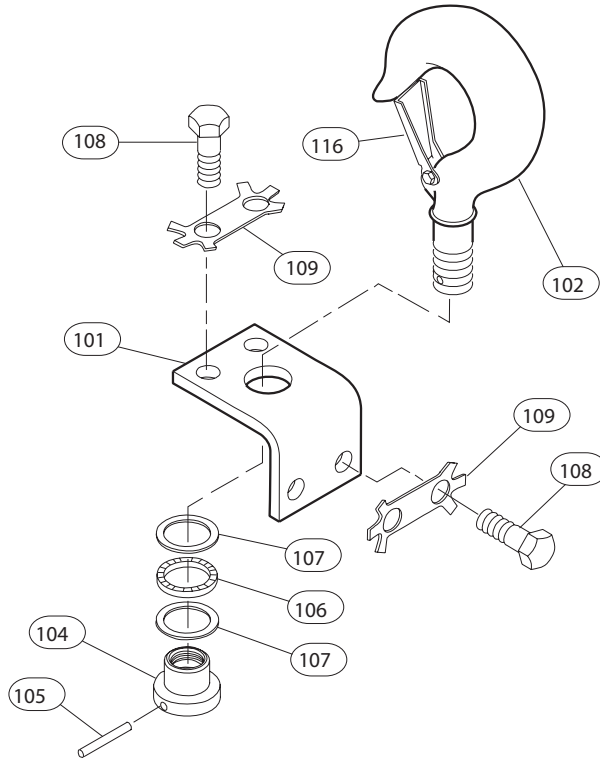

Bottom Hook and Block Assembly for HL1000K, HL1000KR and HL1500K

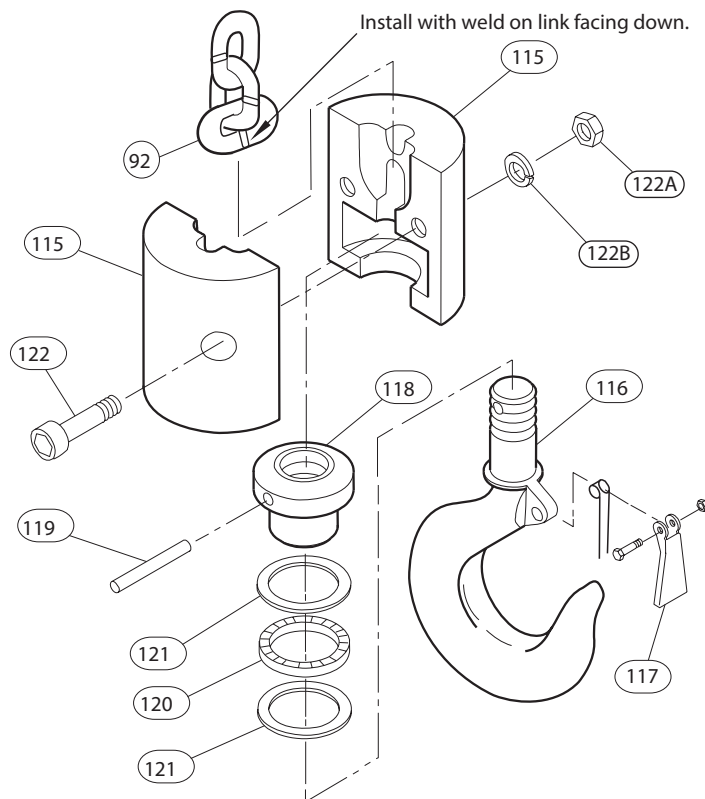

(Dwg. MHP1105)

HL1000K, HL1000KR AND HL1500K HOOK ASSEMBLY PARTS LIST

ITEM No.	DESCRIPTION OF PART	QTY	PART NO.		
			HL1000K and HL1500K		HL1000KR
Load Chain:					
92	Load Chain (Zinc Plated)	Specify Length in Feet	H745Z		---
	Load Chain (Stainless Steel)		---		H745S
Top Hook:			Standard Steel	Bullard Burnham	Bronze
---	Top Hook Assembly	1	HLK-K590	HLK-KBB590	HLK-KR590A
101	Yoke	1	HL1500K-590		
108	Capscrew	4	215-36		
• 109	Locking Tab	2	HLK-322		
---	Hook and Nut Assembly	1	HLK-AS377	HLK-ABB377	---
104	Hook Nut	1	HLK-305		
102	Hook and Latch	1	HLK-S377	HLK-BB377	HL1500K-SR377N
• 116	Latch Kit	1	35023	---	D02-S4055N
• 105	Pin	1	C6H20A-826		
• 106	Bearing	1	HRA60A-379		
• 107	Bearing Washer	2	HLK-465		
Bottom Hook:			Standard Steel	Bullard Burnham	Bronze
---	Bottom Hook Assembly	1	HLK-K463	HLK-KBB463	HLK-KR463A
115	Hook Block	2	HLK-463		HLK-R463
122	Capscrew	2	834-638		
122A	Nut	2	D02-428		
122B	Lockwasher	2	34U-58		
---	Hook and Nut Assembly	1	HLK-AS377	HLK-ABB377	---
118	Hook Nut	1	HLK-305		
116	Hook/Hook and Latch Assembly	1	HLK-377	HLK-BB377	HL1500K-SR377N
• 117	Latch Kit	1	35023	---	40230N
• 119	Pin	1	C6H20A-826		
• 120	Bearing	1	HRA60A-379		
• 121	Bearing Washer	2	HLK-465		

•	Recommended Spare
---	-------------------

HL2000K AND HL3000K HOOK ASSEMBLY PARTS DRAWING

Top hook and Yoke Assembly for Models HL2000K and HL3000K

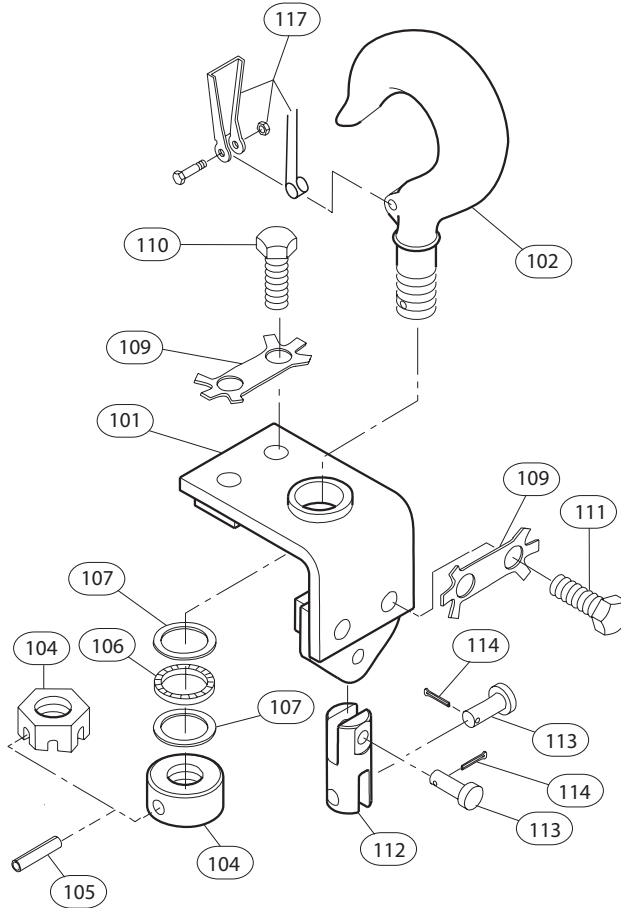

Bottom hook and Block Assembly for Models HL2000K and HL3000K

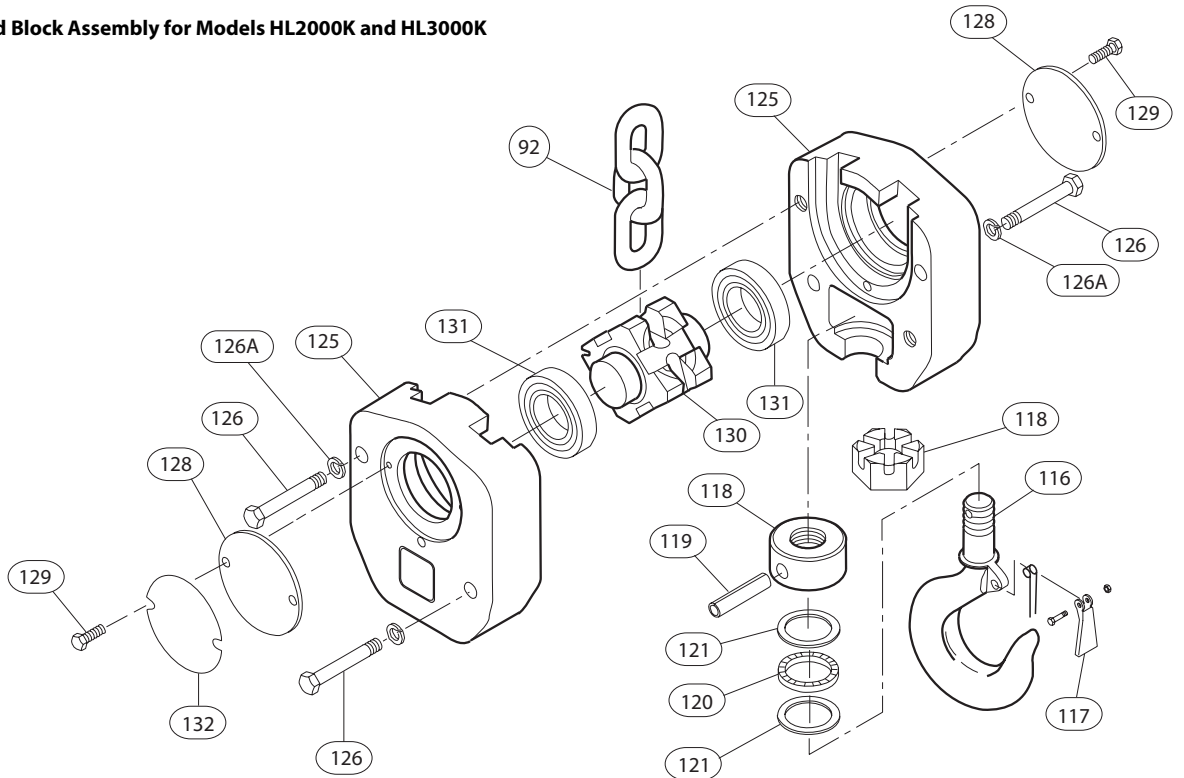

(Dwg. MHP1106)

HL2000K AND HL3000K HOOK ASSEMBLY PARTS LIST

ITEM No.	DESCRIPTION OF PART	QTY	PART NO.					
			HL2000K			HL3000K		
Load Chain:								
92	Load Chain (Zinc Plated)	Specify Length in Feet	H745Z					
Top Hook:			Standard	Bullard Burnham	Bronze	Standard	Bullard Burnham	Bronze
---	Top Hook Assembly	1	HL2000K-K590			HL3000K-K590		
101	Yoke	1	HL3000K-590					
• 109	Locking Tab	2	HLK-322					
110	Capscrew (1.5 in)	2	215-22					
111	Capscrew (2.75 in)	2	HU40-775					
112	Chain Anchor	1	HLK-373					
113	Pin	2	HLK-962					
*114	Cotter Pin	2	D02-330					
---	Hook and Nut Assembly	1	HL2000K-AS377	HL2000K-ABB377	HL2000K-ASR377	HL3000K-AS377	HL3000K-ABB377	HL3000K-ASR377
102	Hook and Latch	1	HL2000K-377	HL2000K-BB377	HL2000K-SR377N	HL3000K-S377	HL3000K-BB377	HL3000K-SR377N
• 117	Latch Kit	1	D04-S4055N	---	45666872	45666880	---	D04-S4055N
104	Hook Nut	1	HL2000K-305A			HL3000K-305		
104A	Hook Nut Spacer **	1	HL2000K-306			---		
• 105	Pin	1	D660A-376					
• 106	Bearing	1	CE110-295					
• 107	Bearing Washer	2	HL3000K-465					
Bottom Hook:			Standard	Bullard Burnham	Bronze	Standard	Bullard Burnham	Bronze
---	Bottom Hook Assembly	1	HL2000K-K378			HL3000K-K378		
125	Hook Block	2	HLK-378					
126	Capscrew	4	AHC68-22					
126A	Lockwasher	4	UW50A30-58					
128	Plate	2	ML50K-981					
129	Screw	4	AF160-305					
130	Idler Chain Wheel	1	HLK-380					
• 131	Bearing	2	BU-359					
132	Load Label	2	HL2000K-99			HL3000K-99		
---	Hook and Nut Assembly	1	HL2000K-AS377	HL2000K-ABB377	HL2000K-ASR377	HL3000K-AS377	HL3000K-ABB377	HL3000K-ASR377
116	Hook and Latch	1	HL2000K-377	HL2000K-BB377	HL2000K-SR377N	HL3000K-S377	HL3000K-BB377	HL3000K-SR377N
• 117	Latch Kit	1	D04-S4055N		45666872	45666880		D04-S4055N
118	Hook Nut	1	HL2000K-305A			HL3000K-305		
118A	Hook Nut Spacer **	1	HL2000K-306			---	---	---
• 119	Pin	1	D660A-376					
• 120	Bearing	1	CE110-295					
• 121	Bearing Washer	2	HL3000K-465					

•	Recomended Spare
**	Indicates not illustrated.

HL4500K HOOK ASSEMBLY PARTS DRAWING

HL4500K UPPER SUSPENSION AND TOP HOOK ASSEMBLY

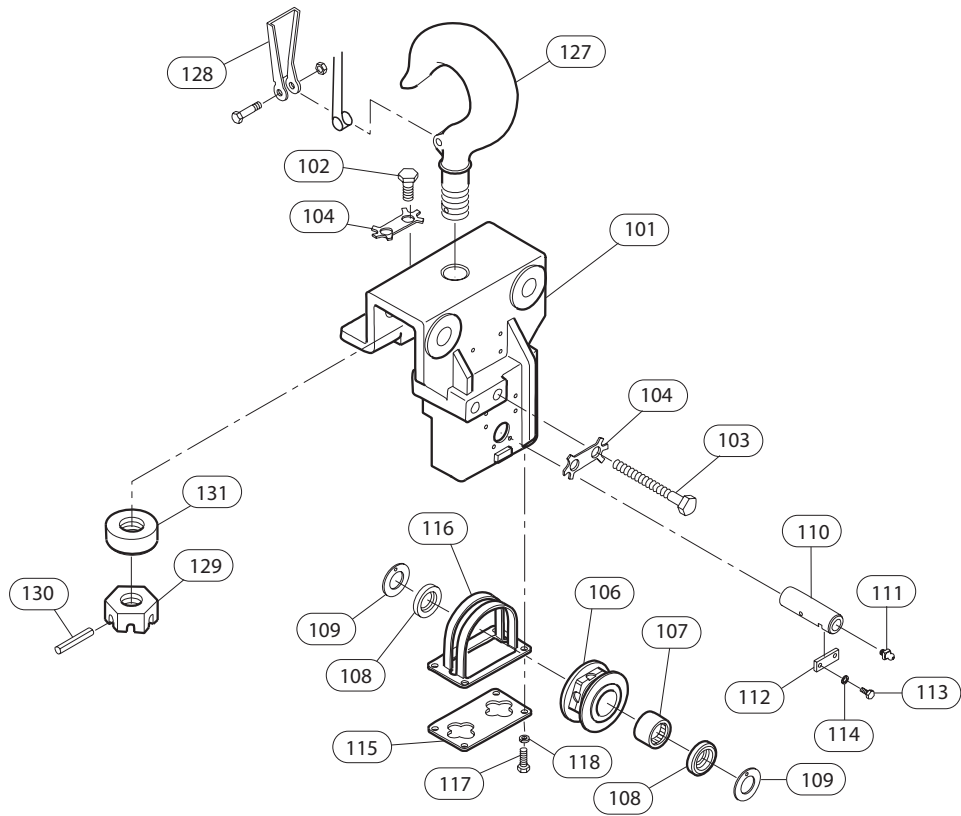

HL4500K BOTTOM HOOK ASSEMBLY

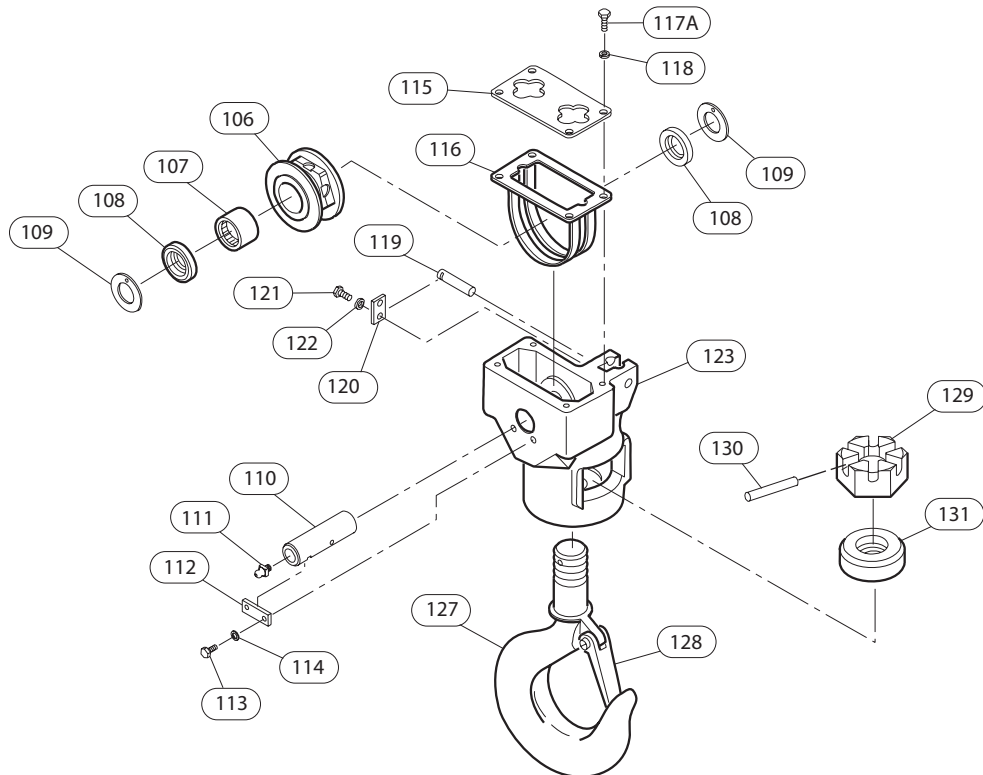

(Dwg.TPA1041)

HL4500K HOOK ASSEMBLY PARTS LIST

ITEM NO.	DESCRIPTION OF PART	QTY.	PART NO.		
			Standard	Bronze	Bullard Burnham
101	Upper Suspension Housing	1	HL4500K-590		
102	Capscrew	2	KX-36		
103	Capscrew	2	D01-339		
104	Tab Washer	2	HLK-322		
106	Idler Wheel Assembly	2	HL6000K-A380		
107	Idler Wheel Bearing	1	48NB-765		
108	Idler Wheel Seal	2	C6H20A28-754		
109	Idler Wheel Thrust Washer	2 each Idler Wheel	HL6000K-974		
110	Idler Wheel Shaft	1 each Idler Wheel	HL6000K-382		
111	Wheel Shaft Grease Fitting	1 each Shaft	R1-188		
112	Wheel Shaft Lockplate	1 each Shaft	MR20-383		
113	Capscrew	2 each Lockplate	JC3350-103		
114	Lockwasher	2 each Lockplate	L01-67-10		
115	Idler Wheel Cover	1 each Idler Wheel	HLK-441		
116	Idler Wheel Chain Guard	1 each Idler Wheel	HLK-445		
117	Capscrew	4 Upper Idler Wheel	R2N-103		
117A	Capscrew	4 Lower Idler Wheel	R3-7-4		
118	Lockwasher	4 Lower Idler Wheel	L01-67-10		
119	Chain Anchor Pin	1	HL6000K-962		
120	Anchor Pin Lockplate	1	HL6000K-462		
121	Capscrew	2	JC3350-103		
122	Lockwasher	2	L01-67-10		
123	Lower Hook Block	1	HL4500K-378		

Top and Bottom Hook:

---	Top and Bottom Hook Assembly	1-Lug Mount	HL4500K-AS377	HL4500K-ASR377	HL4500K-ABB377
		2-Hook Mount			
127	Hook	1	HL4500K-377	HL4500K-SR377N	HL4500K-BB377
• 128	Latch Kit	1	45666880	D10-S4055N	---
129	Hook Nut	1	HL4500K-305		
130	Hook Pin	1	D660A-376		
131	Hook Thrust Bearing	1	HL4500K-379		

•	Recommended Spare
---	-------------------

HL6000K HOOK ASSEMBLY PARTS DRAWING

HL6000K UPPER SUSPENSION AND TOP HOOK ASSEMBLY

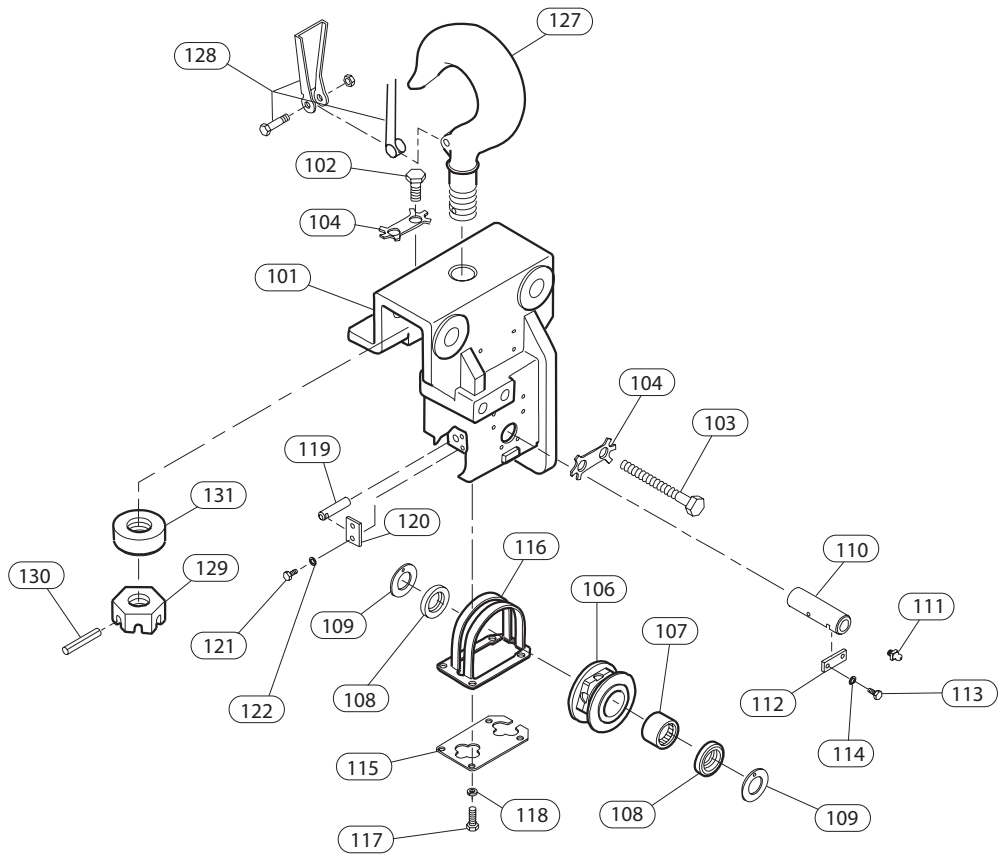

HL6000K BOTTOM HOOK ASSEMBLY

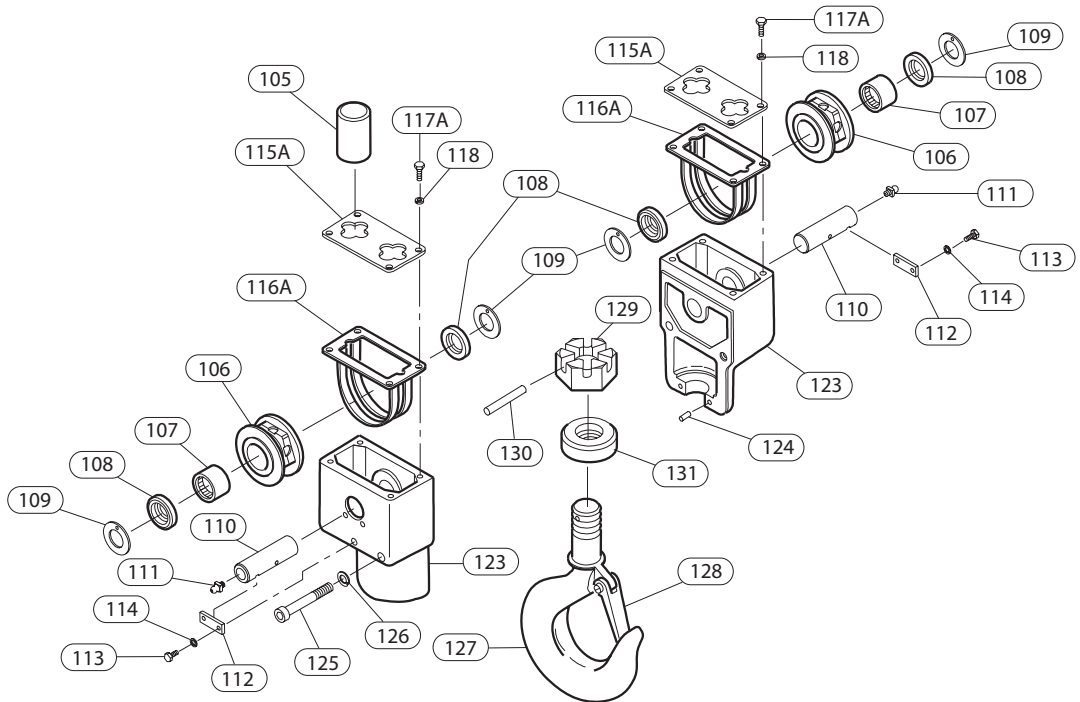

(Dwg.TPA1040)

HL6000K HOOK ASSEMBLY PARTS LIST

ITEM NO.	DESCRIPTION OF PART	QTY.	PART NO.		
			Standard	Bronze	Bullard Burnham
101	Upper Suspension Housing	1	HL6000K-590		
102	Capscrew	2	KX-36		
103	Capscrew	2	D01-339		
104	Tab Washer	2	HLK-322		
105	Limit Stop Tube	1	HL6000K-259		
106	Idler Wheel Assembly	3	HL6000K-A380		
107	Idler Wheel Bearing	1 each Idler Wheel	48NB-765		
108	Idler Wheel Seal	2 each Idler Wheel	C6H20A28-754		
109	Idler Wheel Thrust Washer	2 each Idler Wheel	HL6000K-974		
110	Idler Wheel Shaft	1 each Idler Wheel	HL6000K-382		
111	Wheel Shaft Grease Fitting	1 each Shaft	R1-188		
112	Wheel Shaft Lockplate	1 each Shaft	MR20-383		
113	Capscrew	2 each Lockplate	JC3350-103		
114	Lockwasher	2 each Lockplate	L01-67-10		
115	Idler Wheel Cover (Upper Hook)	1 each Idler Wheel	HL6000K-441		
115A	Idler Wheel Cover (Bottom Hook)		HLK-441		
116	Idler Wheel Chain Guard (Upper Hook)	1 each Idler Wheel	HL6000K-445		
116A	Idler Wheel Chain Guard (Bottom Hook)		HLK-445		
117	Capscrew	4 Upper Idler Wheel	R2N-103		
117A	Capscrew	8 Lower Idler Wheel	R3-7-4		
118	Lockwasher	8 Lower Idler Wheel	L01-67-10		
119	Chain Anchor Pin	1	HL6000K-962		
120	Anchor Pin Lockplate	1	HL6000K-462		
121	Capscrew	2	JC3350-103		
122	Lockwasher	2	L01-67-10		
123	Lower Hook Block	2	HL6000K-378-CP		
124	Pin	2	JC3350-74		
125	Capscrew	2	HLK-638		
126	Lockwasher	2	HRA20A-322		
Top and Bottom Hook:					
---	Top and Bottom Hook Assembly	1-Lug Mount	HL6000K-AS377	HL6000K-ASR377	HL6000K-ABB377
		2-Hook Mount			
127	Hook		HL6000K-377	Order complete hook assembly	
• 128	Latch Kit		45666898	HL6000K-SR4055N	---
129	Hook Nut		D10-305B		
130	Hook Pin		D6100A-376		
131	Hook Thrust Bearing		D10-379A		

• Recommended Spare

PENDANT ASSEMBLY PARTS DRAWING

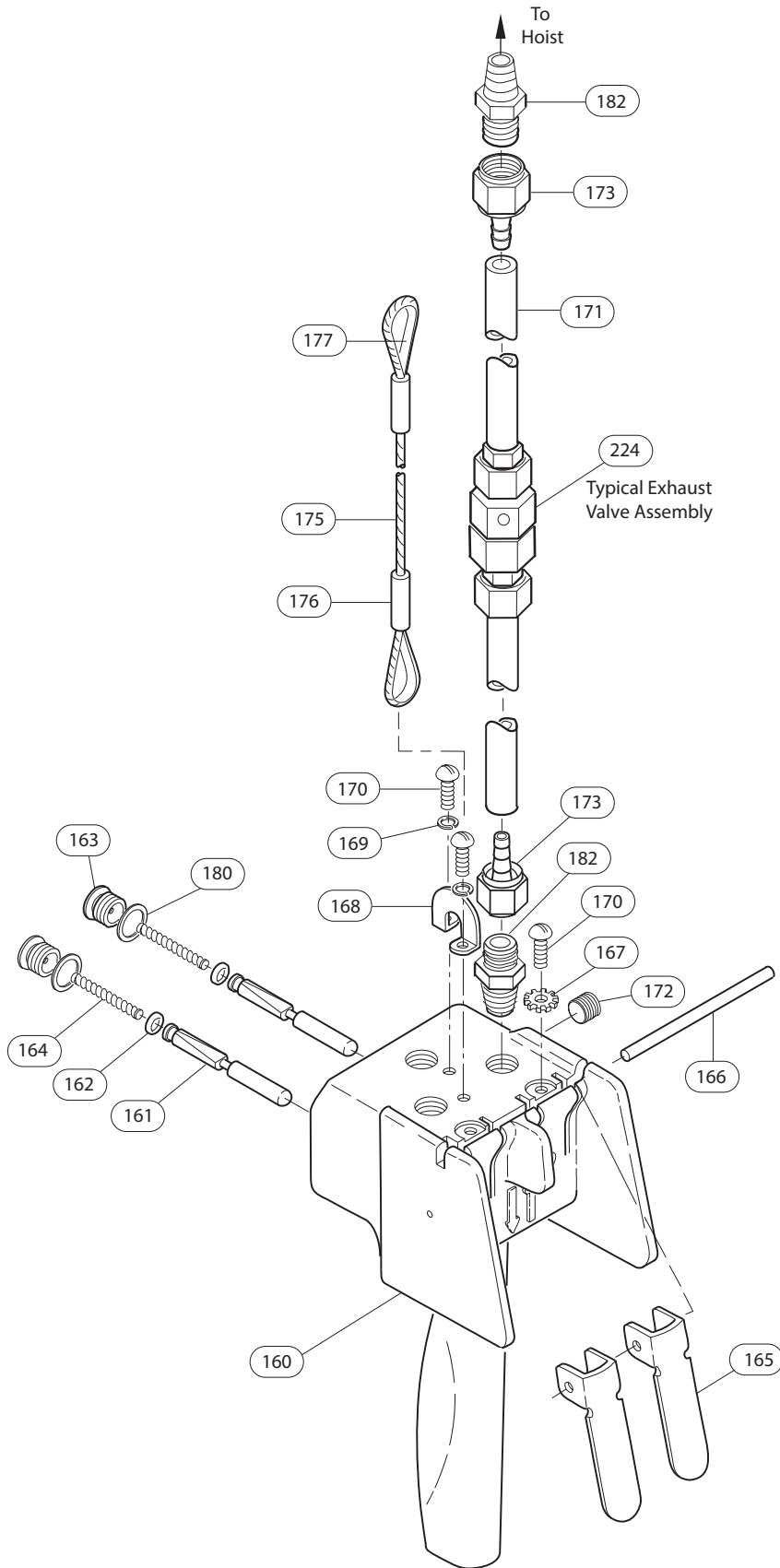

(Dwg.TPA0882-3)

PENDANT ASSEMBLY PARTS LIST

ITEM No.	DESCRIPTION OF PART	QTY	PART NO.	ITEM No.	DESCRIPTION OF PART	QTY	PART NO.
---	Pendant Kit*	1	MLK-K269C	175	Strain Relief Cable (specify length)	1	BWR3A
160	Pendant Assembly **	1	MLK-A269C				
161	Pendant Throttle Valve	2	MLK-K264B	176	Clamping Sleeve (see note 3)	2	MLK-521
• 162	Valve Seal	2	R000BR1C-283	177	Clamping Thimble	2	MLK-602
163	Valve Cap	2	MLK-K266A	• 180	Valve Cap Gasket	2	MLK-504
• 164	Valve Spring	2	MLK-51A	182	Fitting, Hose	5	MLK-165
165	Throttle Lever	2	MLK-273	224	Quick Exhaust Valve Assembly	***	20417
166	Throttle Lever Pin	1	DLC-120A	Parts Not Illustrated			
167	Lockwasher	2	D02-138				
168	Strain Relief Support	1	MLK-450	179	Warning Tag	1	71059612
169	Lockwasher (Pack)	1	H54U-352-10	218	Hose Tie (3 for standard hose; 2 additional each 5 ft hose)		HRE20A-283
170	Handle Screw	4	HRE20A-68		---	Fitting, Elbow (supply air inlet)	
171	Hose (specify length)	3	50923				
172	Plug	1	502-95				
173	Barbed Swivel Fitting	6	51029				
---	Strain Relief Assembly (specify length)	1	MLK-LWR3A				

• Recommended Spare

Additional Pendants and Components:

Single Motor Pendant with Hose Kit	1	MLK-AL269C	Includes all components necessary to install complete pendant assembly. Specify hose length in feet (normally 4 ft (1.2 m) shorter than lift).
Two Motor Pendant		HRA-A122C	Two motor pendant without hose.
Three Motor Pendant		HRA-A132C	Three motor pendant without hose.
Two Motor Pendant (with hose)		MLK-AL122C	Two motor pendant with hose; specify hose length in feet.
Three Motor Pendant (with hose)		MLK-AL132C	Three motor pendant with hose; specify hose length in feet.

* Pendant Kit including items 161 through 173 and 176 through 182.

** Includes 161 through 172, 180 and 182.

*** Quantity of 2 required when hose length exceeds 20 ft (6 m); quantity of 4 required when hose length exceeds 50 ft (16 m).

Notes:

1. Refer to Form P6778 for additional information on pendant throttle handle assemblies.
2. On Old Style valve chests (hoists with the second letter of their serial number A through G or with second and third letters HA, HB, or HC) order (2) MLK-161 adapters. MLK-1671 is a 1/8 NPT to 7/16-20 elbow.
3. A crimping tool (Nicropress® Tool with groove size G) is required to install the clamping sleeves (176).

FABRIC CHAIN CONTAINER ASSEMBLY PARTS DRAWING

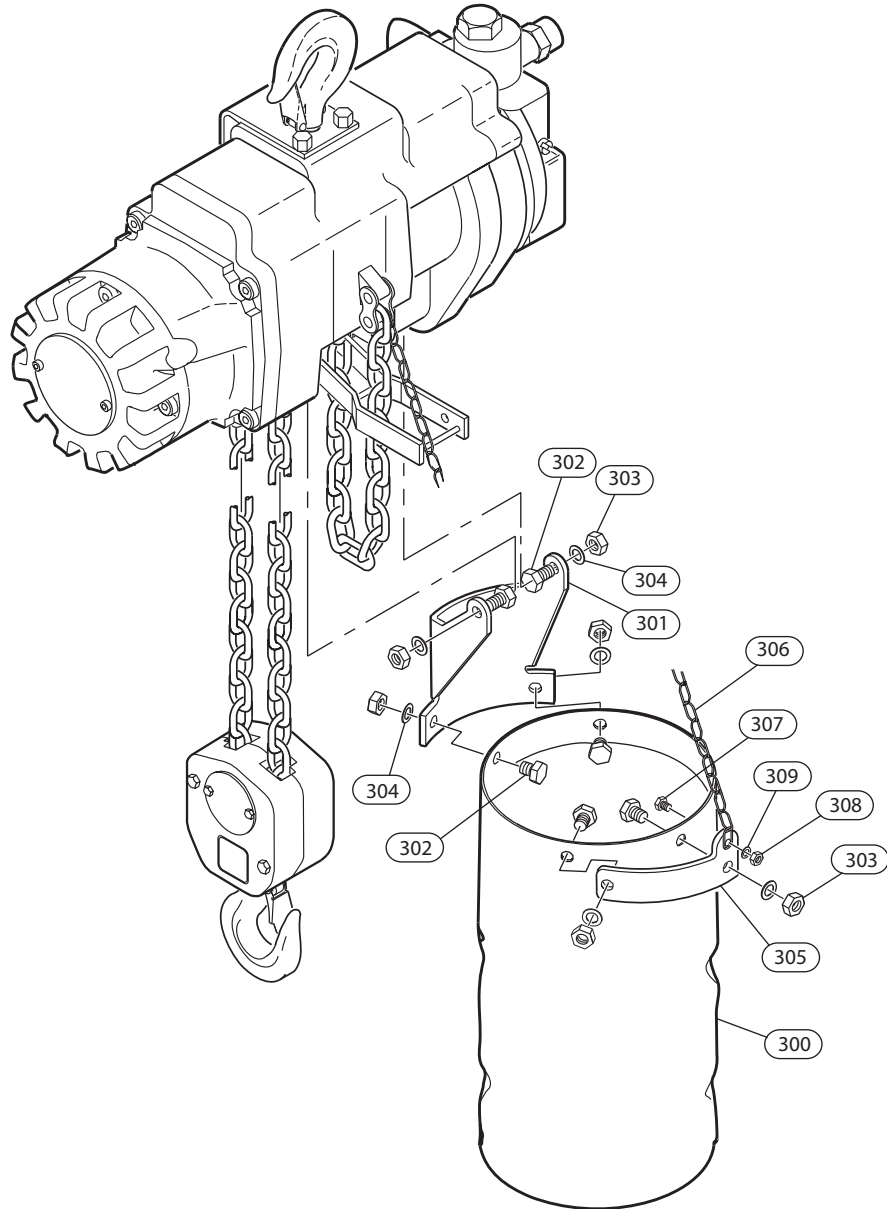

(Dwg.TPC451-3)

FABRIC AND METAL CHAIN CONTAINER ASSEMBLY PARTS LIST

ITEM NO.	DESCRIPTION OF PART	QTY. TOTAL	PART NO.
---	Fabric Chain Container Kit (single fall hoist capacity 20 ft [6 m] or on double fall hoist 10 ft [3 m])	1	HLK-K749-20
	Fabric Chain Container Kit (single fall hoist capacity 40 ft [12 m] or on double fall hoist 20 ft [6 m])		HLK-K749-40
	Metal Chain Container Kit (single fall hoist capacity 20 ft. [6 m] or on double fall hoist 10 ft. [3 m])		HLK-K750-20
	Metal Chain Container Kit (single fall hoist capacity 40 ft. [12 m] or on double fall hoist 20 ft. [6 m])		HLK-K750-40
300	Fabric Chain Container (20 ft [6 m] of chain capacity)	1	HLK-749-20
	Fabric Chain Container (40 ft [12 m] of chain capacity)		HLK-749-40
	Metal Chain Container (20 ft. [6 m] of chain capacity)		HLK-750-20
	Metal Chain Container (40 ft. [12 m] of chain capacity)		HLK-750-40
301	Mounting Bracket	1	HLK-748
302	Bracket Bolt	6	SP9-11B
303	Bracket Nut	6	551AMP61-428
304	Washer	6	B8-259
305	Support Bracket	1	HLK-747
306	Support Chain	1	HLK-240-7
307	Support Bracket Bolt	1	R3H-68A
308	Support Bracket Nut	1	HLK-751
309	Support Bracket Washer	1	R3-94

HLK-K750-85 METAL CHAIN CONTAINER ASSEMBLY PARTS DRAWING

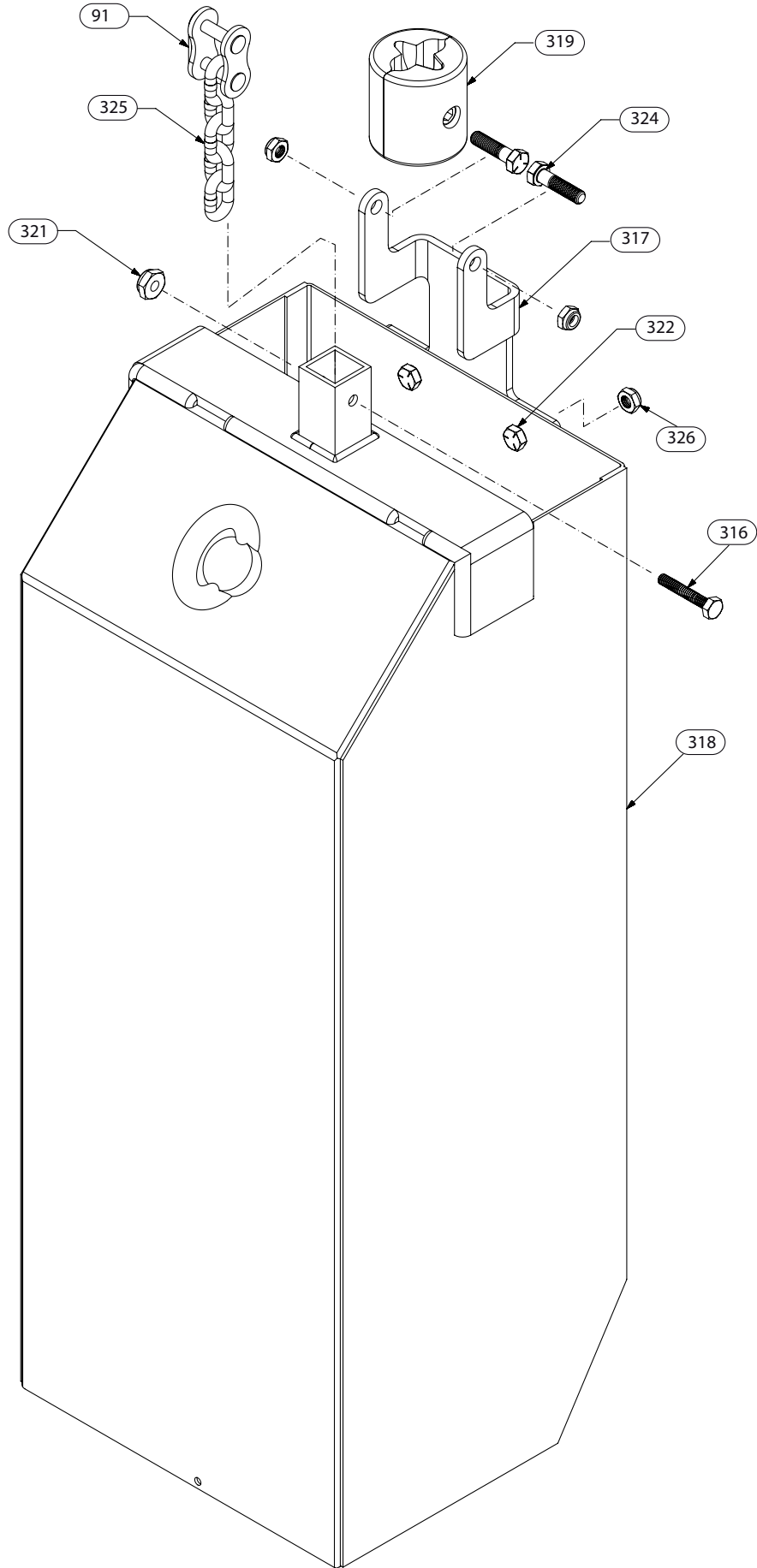

(Dwg. 10552230)

03963832_ed12

HLK-K750-85 METAL CHAIN CONTAINER ASSEMBLY PARTS LIST

ITEM NO.	DESCRIPTION OF PART	QTY. TOTAL	PART NUMBER
---	Metal Chain Container Kit (single fall hoist capacity 80 ft [24 m] or on double fall hoist 40 ft [12 m])		HLK-K750-85
316	Screw	1	10429
317	Bracket	1	04612115
318	Metal Chain Container (80 ft [24 m] of chain capacity)	1	10552222
319	Chain Stop	1	71273353
91	Link	1	HRA30A-646
321	Nut	1	75503
322	Bolt	2	10552248
324	Bolt	2	10552255
325	Chain Link	1	M745Z
326	Nut	4	Y109-524

REPAIR AND CONVERSION KITS

Pendant Conversion Kit: Includes all components necessary to convert a pull chain throttle hoist to pendant control operation. Part No. MLK-AL269C (04307310) used on all MLK, MLKR, HLK and HLKR hoists. Length of pendant hose must be specified when ordering. Pendant length is normally 4 ft (1.2 m) shorter than lift.

Pull Chain Conversion Kit: Part No. MLK-K415 for use on all MLK and HLK hoists. Includes all components necessary, except the pull chains, to convert a pendant throttle hoist to pull chain control operation. Order pull chains separately. See below:
Part No. CA110-B240 (03457769) Pull chain for use on standard HLK hoists. Specify total length of two required pull chains.
Part No. D02-1413 (03170685) Pull chain for use on HL1000KR spark resistant hoists. Specify total length of two required pull chains.

Valve Chest Conversion Kit: Includes all components necessary to convert valve chests used on hoists with second letter of the serial number A through G or with second and third letters of the serial number HA, HB or HC to the same style valve chest used on hoists with second letter of the serial number other than A through G or with second and third letters of the serial number other than HA, HB or HC.
Part No. MLK-K545B (03835519).

Manual Brake Release Kit: Includes all the components for a manual release brake.
Part No. MLK-K390 (03721685) for use on all HLK Hoists.
Part No. MLK-K390H: US Govt. 200% brake capability

Piped Away Exhaust Kit: Part No. MHLK-KEXH. Refer to Dwg. MHP0914.

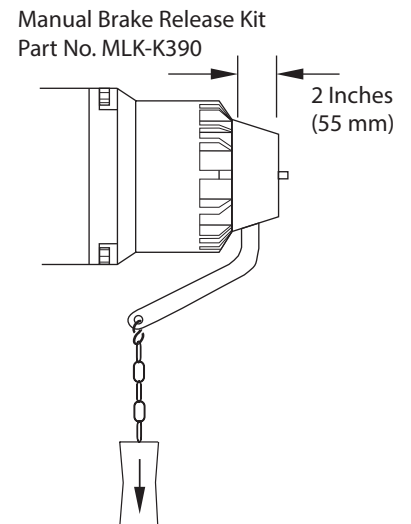
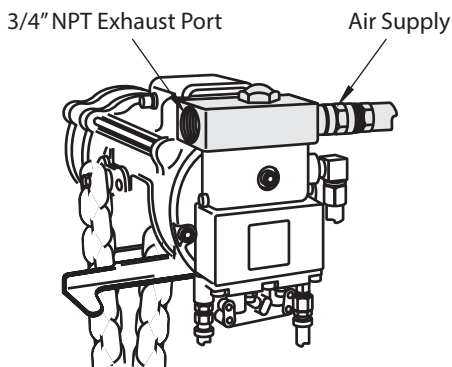

Quick-Exhaust Valves: Must be used on all Hoists with Pendant Control when hoses exceed 20 ft (6 m) in length and includes all fittings and clamps. One quick exhaust valve required for each control hose when length exceeds 20 ft (6 m). Two quick exhaust valves required for each control hose when length exceeds 50 ft (15 m).

Part No. 20417 (71069579) for all HLK Hoists.
Part No. 47541014001 for all trolley or crane motor control hoses.

Overhaul Gasket Kit: Includes gaskets, O-rings and seals for HLK Hoists.
Part No. HLK-K445 (03713740).

Valve Chest Kit:
Part No. MLK-VCK1 Kit. Refer to Dwg. TPA958-1.

Brake Kit:
Part No. MLK-ABK1 Kit. Refer to Dwg. TPB704-3.

ACCESSORIES

PENDANTS AND AIR HOSES

Description of Part	Part No.	Notes
Two Motor Pendant	HRA-A122C (03709177)	Order hose separately.
Three Motor Pendant	HRA-A132C (03709219)	
Two Motor Pendant and Hose Assembly	MLK-AL122C (04307336)	Specify hose length in feet.
Three Motor Pendant and Hose Assembly	MLK-AL132C (04307344)	
Precoiled Air Hose 1/2 in x 25 ft (13 mm x 8 m)	N12-25B	Hose sizes refer to inside diameter (ID).
Precoiled Air Hose 3/4 in x 25 ft (19 mm x 8 m)	N34-25B	
Precoiled Air Hose 3/4 in x 50 ft (19 mm x 15 m)	N34-50B	

Description of Accessory	Part No.
Chain Lubricant	LUBRI-LINK-GREEN

PARTS ORDERING INFORMATION

HLK Hoists are designed and constructed to provide long, trouble-free service. In time it may become necessary to order and install new parts to replace those that have been subjected to wear.

The use of other than **Ingersoll Rand** Material Handling replacement parts may result in decreased hoist performance, and may, at the company's option invalidate the warranty. For prompt service and genuine Ingersoll Rand Material Handling parts, provide your nearest distributor with the following:

1. Complete hoist model number and serial number as it appears on the nameplate.
2. Part number and part description as shown in this manual.
3. Quantity required.

The serial number label is located on the hoist housing.



The model number label is located on the hoist housing.

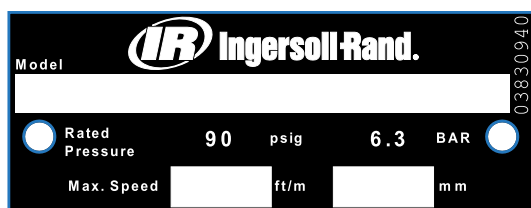

For your convenience and future reference it is recommended that the following information be recorded.

Hoist Model Number _____

Hoist Serial Number _____

Date Purchased _____

Return Goods Policy

If it becomes necessary to return the complete hoist or certain parts to the factory, contact the distributor from whom you purchased the hoist, or the nearest **Ingersoll Rand** distributor in your locality.

Ingersoll Rand will not accept any returned goods for warranty or service work unless prior arrangements have been made and written authorization has been provided from the location where the goods were purchased.

NOTICE

• **Continuing improvement and advancement of design may cause changes to this hoist which are not included in this manual. Manuals are periodically revised to incorporate changes. Always check the manual edition number on the front cover for the latest issue.**

Disposal

When the life of the hoist has expired, it is recommended that the hoist be disassembled, degreased and parts separated as to materials so that they may be recycled.

NOTICE

• **Mineral based oils can be recycled, however, some oils such as glycols may be extremely toxic and must be identified and disposed of in accordance with local, state and national regulations.**

For additional information contact Ingersoll Rand Factory or the Nearest distributor:

Ingersoll Rand
20017 72nd Avenue South
Kent, WA 98032 USA
Phone: (877) 584-0370
Fax: (206)-624-6265

For additional information on the following products order the Publication by the referenced Part/Document Number listed:

Publication	Part/Document No.
TIR Trolley	MHD56083
PT/RT Trolley	MHD56102
TP3A-K430 and TP3A-K430T	P6719
CE120-K426 and CE120-K426T	P6720
TP3A-K426 and TP3A-K426T	P6723
CE120-K430 and CE120-K430T	P6725
TP6A-K430 and TP6A-K430T	P6743
TP6A-K426 and TP6A-K426T	P6744
MLK Hoist	P6554
HRA40A-A700 and HRA40A-AT700	Contact factory

WARRANTY

LIMITED WARRANTY

Ingersoll Rand Company (“IR”) warrants to the original user its industrial lifting equipment (“Hoist”) to be free of defects in material and workmanship for a period of one year from the date of purchase. IR will, at its option either (1) repair, without cost, any Hoist found to be defective, including parts and labor charges, or (2) replace such Hoist or refund the purchase price, less a reasonable allowance for depreciation, in exchange for the Hoist. Repairs or replacements are warranted for the remainder of the original warranty.

If any Hoist proves defective within its original one-year warranty period, it should be returned to any Authorized Hoist Service Distributor, transportation prepaid with proof of purchase or warranty card. This warranty does not apply to Hoists which IR has determined to have been misused or abused, improperly maintained by the user, or where the malfunction or defect can be attributed to the use of non-genuine IR repair parts.

IR MAKES NO OTHER WARRANTY, CONDITION OR REPRESENTATION OF ANY KIND WHATSOEVER, EXPRESSED OR IMPLIED, STATUTORY OR OTHERWISE, AND ALL IMPLIED WARRANTIES AND CONDITIONS RELATING TO MERCHANTABILITY AND FITNESS FOR A PARTICULAR PURPOSE, ARE HEREBY DISCLAIMED.

IR’s maximum liability is limited to the purchase price of the Hoist and in no event shall IR be liable for any consequential, indirect incidental or special damages of any nature arising from the sale or use of the Hoist, whether in contract, tort or otherwise.

Note: Some states do not allow limitations on incidental or consequential damages, so that the above limitations may not apply to you. This warranty gives you specific legal rights and you may also have other rights which may vary from state to state.

IMPORTANT NOTICE

It is our policy to promote safe delivery of all orders.

This shipment has been thoroughly checked, packed and inspected before leaving our plant and receipt for it in good condition has been received from the carrier. Any loss or damage which occurs to this shipment while en route is not due to any action or conduct of the manufacturer.

Visible Loss or Damage

If any of the goods called for on the bill of lading or express receipt are damaged or the quantity is short, do not accept them until the freight or express agent makes an appropriate notation on your freight bill or express receipt.

Concealed Loss or Damage

When a shipment has been delivered to you in apparent good condition, but upon opening the crate or container, loss or damage has taken place while in transit, notify the carrier’s agent immediately.

Damage Claims

You must file claims for damage with the carrier. It is the transportation company’s responsibility to reimburse you for repair or replacement of goods damaged in shipment. Claims for loss or damage in shipment must not be deducted from the **Ingersoll Rand** invoice, nor should payment of **Ingersoll Rand** invoice be withheld awaiting adjustment of such claims as the carrier guarantees safe delivery.

You may return products damaged in shipment to us for repair, which services will be for your account and form your basis for claim against the carrier.

